

Before inspecting the fuel system, perform the minimum inspection for compression and ignition system.

Carburettor Check Sheet

GX630/660/690

1 3 4 8 9 : Priority check Points

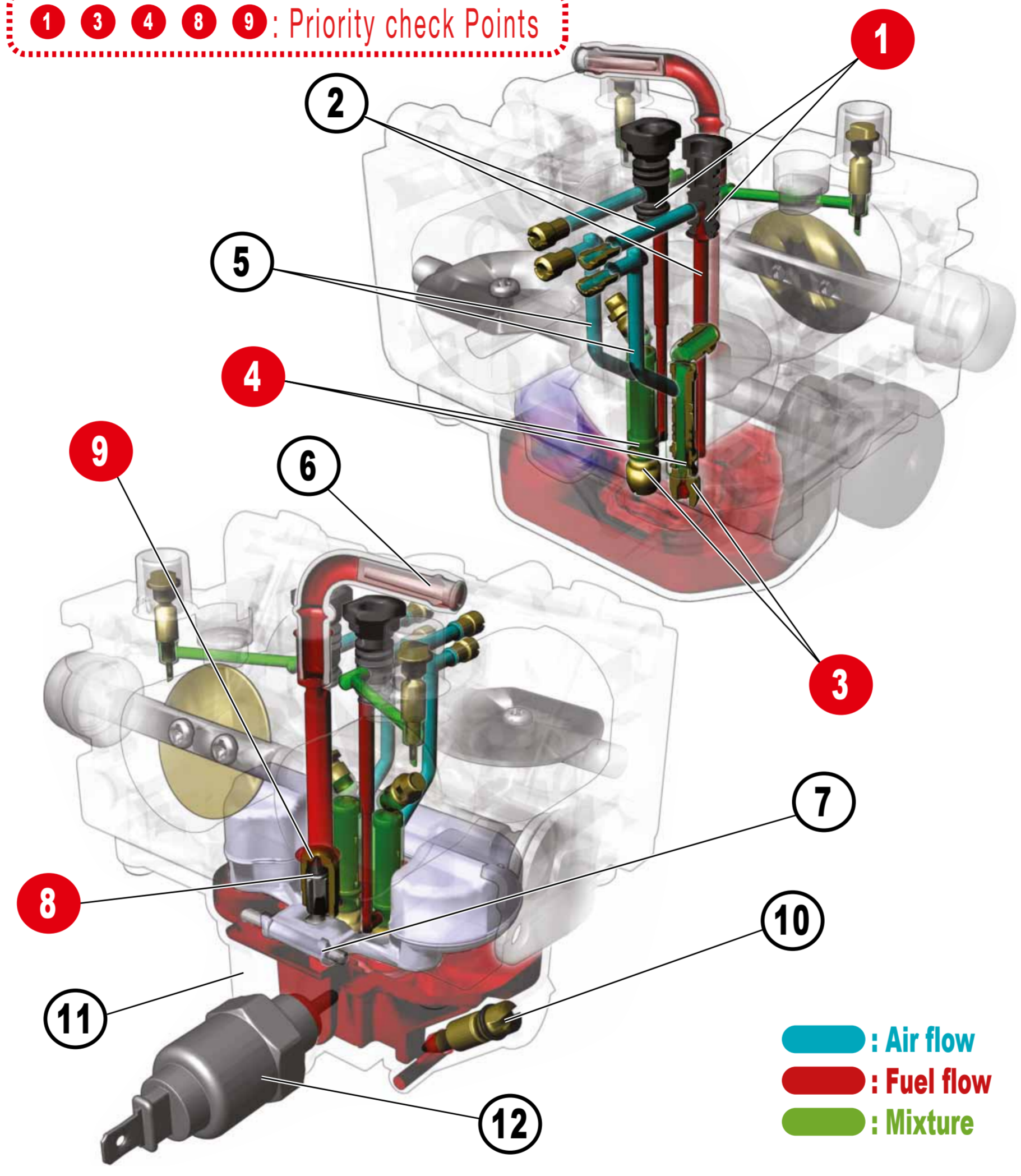

◆ Poor performance at low speed
◆ Unstable idle speed

1 Pilot jet clogged. Remove foreign materials/dirt. Use needle B (Φ 0.3) to clean.

2 Pilot jet air path clogged. Remove foreign materials/dirt.

◆ Engine does not start or stop
◆ Hard starting
◆ Engine starts but quickly stops

3 Main jet clogged. Remove foreign materials/dirt. Use needle A (Φ 0.5) to clean.

4 Main nozzle clogged. Remove foreign materials/dirt.

5 Main nozzle air path clogged. Remove foreign materials/dirt.

6 Fuel strainer screen clogged. Blow air and check the screen for clogging.

7 Float doesn't move properly. Remove foreign materials around float pin.

11 Check of float chamber
Water inside Float chamber cause engine failure. Take off Float chamber and clean.

12 Fuel cut solenoid valve
Connect the 12V battery to the fuel cut solenoid valve connector as shown. Check the needle of the valve should retract in.

Using of Carburetor Cleaning Kit (Kit No.07JPZ-0010000)
Carburetor cleaning kit is useful to remove foreign materials/dirt.

Needle A (Φ 0.5) (Main jet)	Needle B (Φ 0.3) (Pilot jet)	Pump nozzle (Air blow to jets and Air paths)	Screw driver (Main jet assemble/disassemble)
-----------------------------	------------------------------	--	--

◆ Engine speed does not increase
◆ Poor performance at high speed
◆ Unstable engine speed

1 Pilot jet clogged. Remove foreign materials/dirt. Use needle B (Φ 0.3) to clean.

2 Pilot jet air path clogged. Remove foreign materials/dirt.

3 Main jet clogged. Remove foreign materials/dirt. Use needle A (Φ 0.5) to clean.

4 Main nozzle clogged. Remove foreign materials/dirt.

5 Main nozzle air path clogged. Remove foreign materials/dirt.

6 Fuel strainer screen clogged. Blow air and check the screen for clogging.

◆ Overflow
◆ Gasoline leaks

8 Float valve worn or coated with foreign materials/dirt. Remove foreign materials/dirt.

9 Valve seat worn or coated with foreign materials/dirt. Remove foreign materials/dirt. Don't damage the seat surface.

10 For long storage of the engine (More than 3 months).
Drain gasoline from float chamber by running the engine until it stops or by loosening the drain screw while engine is stopped.