

# Honda Engines Parts & Accessories

*A genuine part can make the difference*

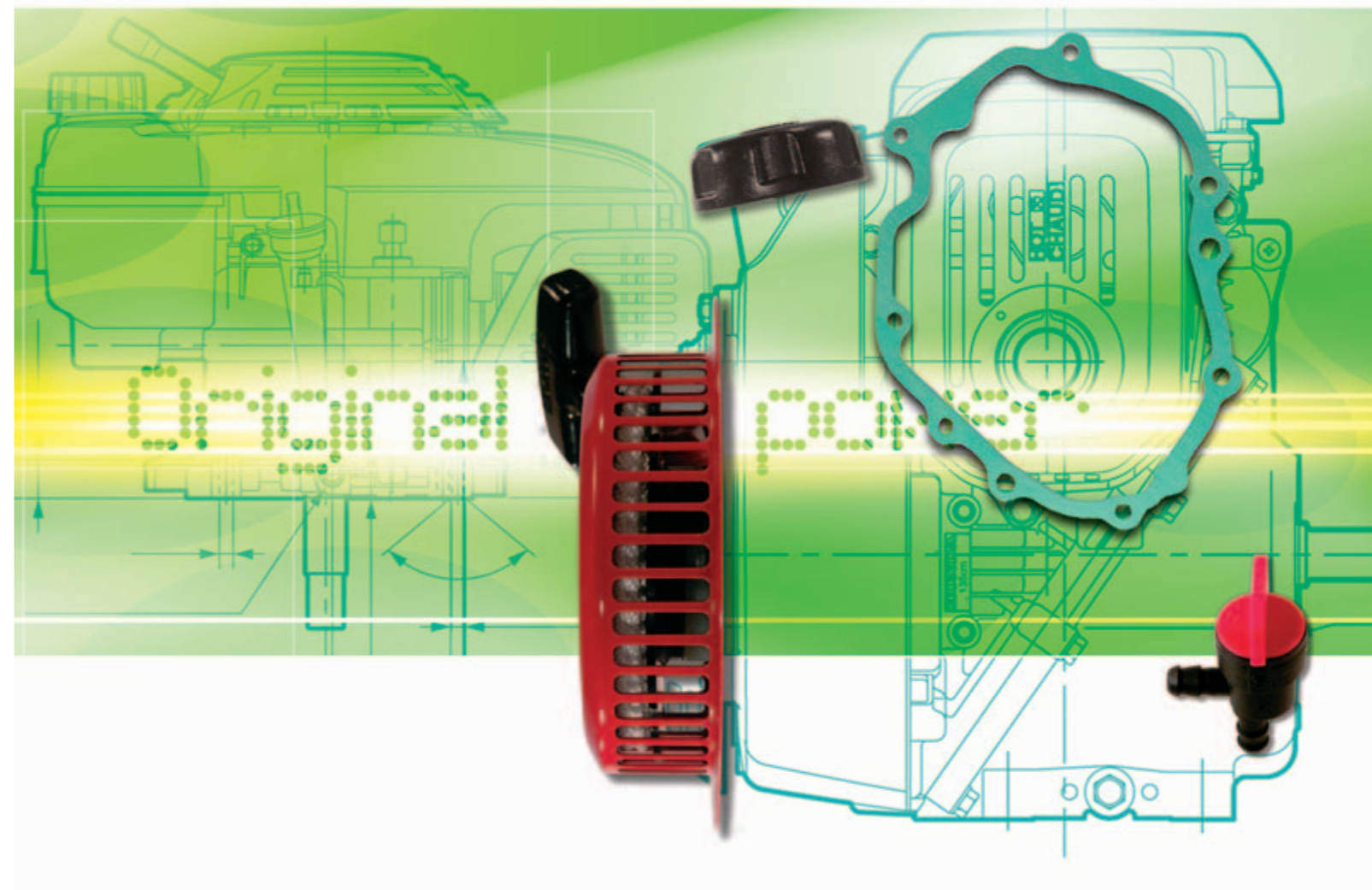
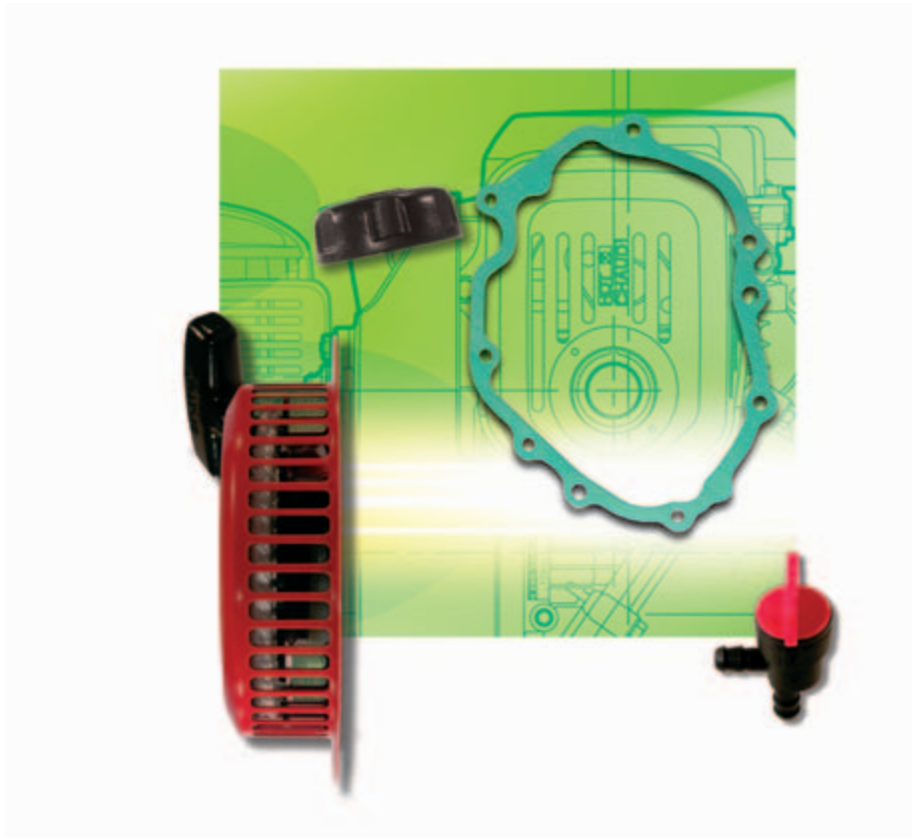

**Honda Europe NV**  
Langerbruggestraat 104  
B-9000 Gent

# Engine models



| Engine model | Model code | Engine serial no |         |
|--------------|------------|------------------|---------|
|              |            | From             | To      |
| G100K1       | G100-      | 2000001          | 2424874 |
| G100K2       | G100-      | 3000001          | 9999999 |
| G150         | G150-      | 1000001          | 9000000 |
| G150K1       | G150-      | 9100001          | 9999999 |
| G200         | G200-      | 1000001          | 9000000 |
| G200K1       | G200-      | 9100001          | 9999999 |
| GC135        | GCAJ-      | 1000001          | 9999999 |
| GC160        | GCAH(A)-   | 1000001          | 9999999 |
| GC190A       | GCAAA-     | 1000001          | 9999999 |
| GX22         | GCAF-      | 1000001          | 9999999 |
| GX31         | GCAJ-      | 1000001          | 9999999 |
| GX35         | GCAJ-      | 1000001          | 9999999 |
| GX35T        | GCAJ-      | 1000001          | 9999999 |
| GX35N        | GCAJ-      | 1000001          | 9999999 |
| GX35NT       | GCAJ-      | 1000001          | 9999999 |
| GX25         | GCAAM-     | 1000001          | 9999999 |
| GX25N        | GCAAM-     | 1000001          | 9999999 |
| GX25T        | GCAAM-     | 1000001          | 9999999 |
| GX25NT       | GCAAM-     | 1000001          | 9999999 |
| GXH50        | GCAH-      | 1000001          | 9999999 |
| GXH50U       | GCAH-      | 1000001          | 9999999 |
| GX100        | GCANM-     | 1000001          | 9999999 |
| GX100U       | GCAH-      | 1000001          | 9999999 |
| GX120K1      | GCD1-      | 2000001          | 9999999 |
| GX120T1      | GCAAT-     | 1000001          | 9999999 |
| GX120U1      | GCAH-      | 1000001          | 9999999 |
| GX120U1T1    | GCAH-      | 1000001          | 9999999 |
| GX160K1      | GCD2-      | 2000001          | 9999999 |
| GX160T1      | GCAH-      | 1000001          | 9999999 |
| GX160U1      | GCAH-      | 1000001          | 9999999 |
| GX160U1T1    | GCAH-      | 1000001          | 9999999 |
| GX160UH1     | GCAH-      | 1000001          | 9999999 |
| GX200        | GCAE-      | 1000001          | 9999999 |
| GX200T       | GCAE-      | 1000001          | 9999999 |
| GX200U       | GCAJ-      | 1000001          | 9999999 |
| GX200UT      | GCAH-      | 1000001          | 9999999 |

| Engine model | Model code    | Engine serial no |         |
|--------------|---------------|------------------|---------|
|              |               | From             | To      |
| GX240K1      | GCD4-         | 3000001          | 9999999 |
| GX240U1      | GCAKK-        | 1000001          | 9999999 |
| GX270        | GCAB-         | 1000001          | 9999999 |
| GX270U       | GCALK-        | 1000001          | 9999999 |
| GX270UT      | GCAJT-        | 1000001          | 9999999 |
| GX340K1      | GCD5-         | 2000001          | 9999999 |
| GX340U1      | GCAMK-        | 1000001          | 9999999 |
| GX360K1      | GA01-         | 1100001          | 9999999 |
| GX390T1      | GCAET-        | 1000001          | 9999999 |
| GX390K1      | GCAA-         | 2000001          | 9999999 |
| GX390U1      | GCANK-        | 1000001          | 9999999 |
| GX390U1T1    | GCAKT-        | 1000001          | 9999999 |
| GX440U       | GCAWK-        | 1000001          | 9999999 |
| GX640        | GAAD-         | 1000001          | 9999999 |
| GX610        | GCAC-         | 1000001          | 1999999 |
| GX620        | GCAD-         | 1000001          | 1999999 |
| GX610K1      | GCAC-         | 2000001          | 9999999 |
| GX610U1      | GCAPK-        | 1000001          | 9999999 |
| GX620K1      | GCAD-         | 2000001          | 9999999 |
| GX620U1      | GCARK-        | 1000001          | 9999999 |
| GX670        | GCAM-         | 1000001          | 9999999 |
| GX670U       | GCASK-        | 1000001          | 9999999 |
| GS160A       | GCABA-        | 1000001          | 9999999 |
| GS190A       | GCACA-        | 1000001          | 9999999 |
| GV100K1      | GV100-        | 2000001          | 2999999 |
| GV100K2      | GV100-        | 910001           | 9999999 |
| GCV135       | GJAF-         | 1000001          | 9999999 |
| GCV135E      | GJAFE-        | 1000001          | 9999999 |
| GCV160A      | GJAEA-        | 1000001          | 9999999 |
| GCV160       | GJAE-         | 1000001          | 9999999 |
| GCV190A      | GJAAA-        | 1000001          | 9999999 |
| GCV520       | GJAKM-/GJANM- | 1000001          | 9999999 |
| GCV530       | GJAJM-/GJAMM- | 1000001          | 9999999 |
| GXV50        | GJAG-         | 1000001          | 9999999 |
| GXV50U       | GJAAK-        | 1000001          | 9999999 |
| GXV120       | GXV120-       | 1000001          | 9999999 |
| GXV140       | GJAB-         | 6000001          | 9999999 |
| GXV160       | GJ03-         | 1000001          | 5999999 |
| GXV160K1     | GJ03-         | 6000001          | 9999999 |
| GXV160H2     | GJAAH         | 1000001          | 9999999 |
| GXV160UH2    | GJABH-        | 1000001          | 9999999 |
| GXV270K1     | GJ01-         | 2000001          | 9999999 |
| GXV340T2     | GJABT         | 1000001          | 9999999 |
| GXV340K1     | GJ02-         | 1100001          | 5999999 |
| GXV340K2     | GJ02-         | 6000001          | 9999999 |
| GXV340UT2    | GJACT-        | 1000001          | 9999999 |
| GXV390T1     | GJAAT         | 1000001          | 9999999 |
| GXV390K1     | GJAA-         | 6000001          | 9999999 |
| GXV390U1T1   | GJADT-        | 1000001          | 9999999 |
| GXV520       | GJAPM-        | 1000001          | 9999999 |
| GXV530       | GJARM-        | 1000001          | 9999999 |
| GXV530U      | GJAEK-        | 1000001          | 9999999 |
| GXV610       | GJAC-         | 1000001          | 1999999 |
| GXV620       | GJAD-         | 1000001          | 1999999 |
| GXV610K1     | GJAC-         | 2000001          | 9999999 |
| GXV620K1     | GJAD-         | 2000001          | 9999999 |
| GXV620U1     | GJAGK-        | 1000001          | 9999999 |
| GXV670       | GJAH-         | 1000001          | 9999999 |
| GXV670U      | GJAHK-        | 1000001          | 9999999 |
| GSV160A      | GJABA         | 1000001          | 9999999 |
| GSV190A      | GJACA         | 1000001          | 9999999 |

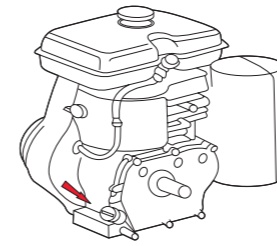

G 100/150/200

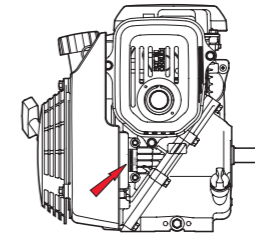

GC 135/160/190 - GS 160/190

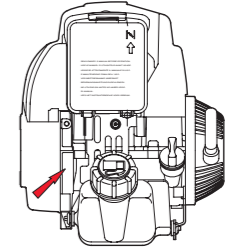

GX 22/31

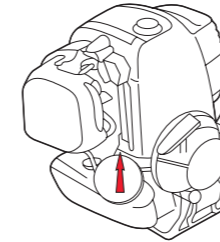

GX 25/35

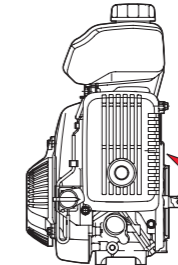

GXH 50

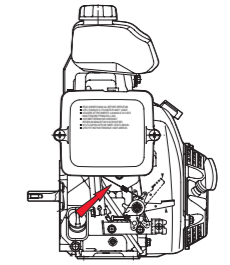

GX 100

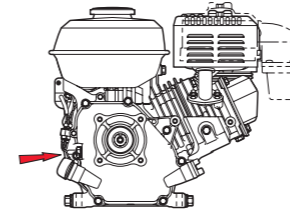

GX 120/160/200/240/270/340/390

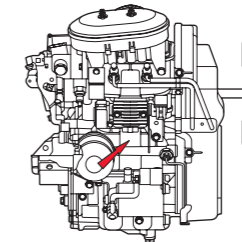

GX 360K1 - GX640

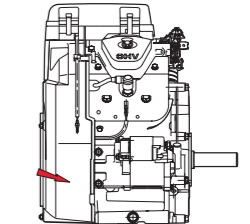

GX 610/620/670

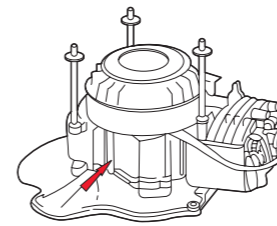

GV 100

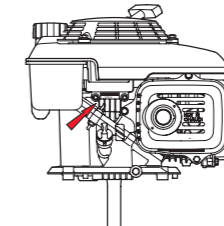

GCV 135/160/190 - GSV 160/190

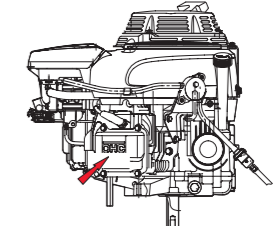

GCV 520/530

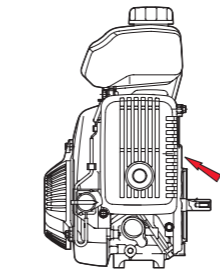

GXV 50

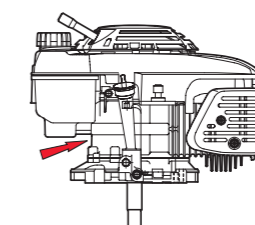

GXV 120/140/160 - GXV 160K1

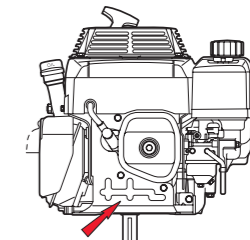

GXV 270/340

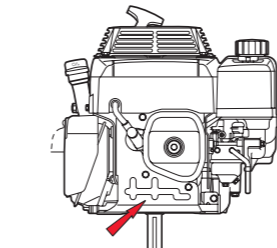

GXV 390

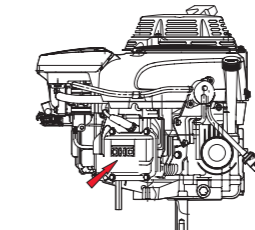

GXV 520/530

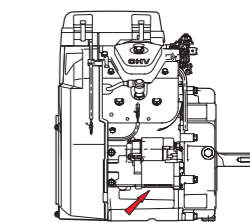

GXV 610/620/670





# Ignition coil

| Engine model    | REF. | Ignition coil                                 |
|-----------------|------|---|
| G 100K1         | 1    | 30500-ZG0-813                                 |
| G 100K2         | 1    | 30500-ZG0-W01                                 |
| G 150           | 3    | 30560-887-T00                                 |
| G 150K1         | 1    | 30500-883-R51                                 |
| G 200           | 3    | 30560-883-015                                 |
| G 200K1         | 1    | 30500-883-R51                                 |
| GC 135          | 1    | 30500-ZL8-004                                 |
| GC 160          |      |   |
| GC 190          |      | 30500-Z0J-003                                 |
| GX 22           | 1    | 30500-ZM3-003                                 |
| GX 31           |      |   |
| GX 35           |      | 30500-Z0Z-013                                 |
| GX 35T          | 1    | 30500-Z3F-003                                 |
| GX 35N          |      | 30500-Z0Z-013                                 |
| GX 35NT         |      | 30500-Z3F-003                                 |
| GX 25           |      | 30500-Z0H-023                                 |
| GX25T           | 1    | 30500-Z3E-003 ( 30500-Z0H-801 type TEZ-TEZR ) |
| GX25N           | 1    | 30500-Z0H-023 ( 30500-Z0H-801 type TZR3-TZ3 ) |
| GX25NT          | 1    | 30500-Z3E-003                                 |
| GXH 50          | 1    | 30500-ZM7-004                                 |
| GXH 50U         | 1    |   |
| GX 100 STD      | 1    | 30500-Z0D-013                                 |
| GX 100 TAMP     | 1    | 30500-Z0D-V02                                 |
| GX 100 U        |      |   |
| GX 120K1        | 2    | 30500-ZE1-063                                 |
| GX 120U1        |      |   |
| GX 120T1        |      | 30500-Z0T-801                                 |
| GX 120UT1       |      |   |
| GX 160K1        |      | 30500-ZE1-063                                 |
| GX 160T1        |      | 30500-Z0T-801                                 |
| GX 160H1        |      | 30500-Z1T-003                                 |
| GX 160U1        |      | 30500-ZE1-063                                 |
| GX 160UT1       |      | 30500-Z0T-801                                 |
| GX 200 / U      |      | 30500-ZE1-063                                 |
| GX 200T / UT    |      | 30500-Z0T-801                                 |
| GX 240K1 / U1   | 2    | 30500-ZF6-W02                                 |
| GX 270 / U      |      |   |
| GX 340K1 / U1   |      |   |
| GX 390K1 / U1   |      |   |
| GX 390T1 / UT1  |      |   |
| GX 360K1        | 5    | 30500-ZA0-701 (CYL. 1 + CYL. 2)               |
| GX440U          | 6    | 30520-Z2E-003                                 |
| GX 640          | 3    | 30500-ZG8-003 (CYL. 1 + CYL. 2)               |
| GX 610          | 2    | 30500-ZJ1-023(CYL.1)/30550-ZJ1-023(CYL.2)     |
| GX 620          |      |   |
| GX 610K1 / U1   | 2    | 30500-ZJ1-844(CYL.1)/30550-ZJ1-844(CYL.2)     |
| GX 620K1 / U1   |      |   |
| GX 670 / U      |      |   |
| GS 160          | 1    | 30500-Z0J-003                                 |
| GS 190          |      |   |
| GV 100K1        | 1    | 30500-ZG1-U10                                 |
| GV 100K2        |      | 30500-ZL1-004                                 |
| GCV 135         | 1    | 30500-ZL8-004                                 |
| GCV 135E        |      |   |
| GCV 160A        |      |   |
| GCV 160         |      |   |
| GCV 190         |      | 30500-Z0J-003                                 |
| GCV 520         | 1    | 30500-Z0A-033(CYL.1)/30550-Z0A-033(CYL.2)     |
| GCV 530         |      |   |
| GXV 50          | 1    | 30500-ZM7-004                                 |
| GXV50 U         |      |   |
| GXV 120         | 2    | 30500-ZG9-M04                                 |
| GXV 140         | 1    | 30500-ZG9-801                                 |
| GXV160          | 2    | 30500-ZE7-063                                 |
| GXV 160H2 / UH2 | 2    | 30500-Z1V-003                                 |
| GXV 160K1       |      | 30500-ZG9-801                                 |
| GXV 270K1       | 2    | 30500-ZF5-003                                 |
| GXV 340K1       | 2    | 30500-ZE9-L33                                 |
| GXV 340K2       |      |   |
| GXV 340T2 / UT2 |      | 30500-Z1E-013                                 |
| GXV 390T1 / UT1 |      |   |
| GXV 390K1       |      | 30500-ZE9-L33                                 |
| GXV 520         | 1    | 30500-Z0A-033(CYL.1)/30550-Z0A-033(CYL.2)     |
| GXV 530 / U     |      |   |
| GXV 610         | 2    | 30500-ZJ1-013                                 |
| GXV 620         |      |   |
| GXV 610K1       | 2    | 30500-ZJ1-844(CYL.1)/30550-ZJ1-844(CYL.2)     |
| GXV 620K1 / U1  |      |   |
| GXV 670 / U     |      |   |
| GSV 160         | 1    | 30500-Z0J-003                                 |
| GSV 190         |      |   |

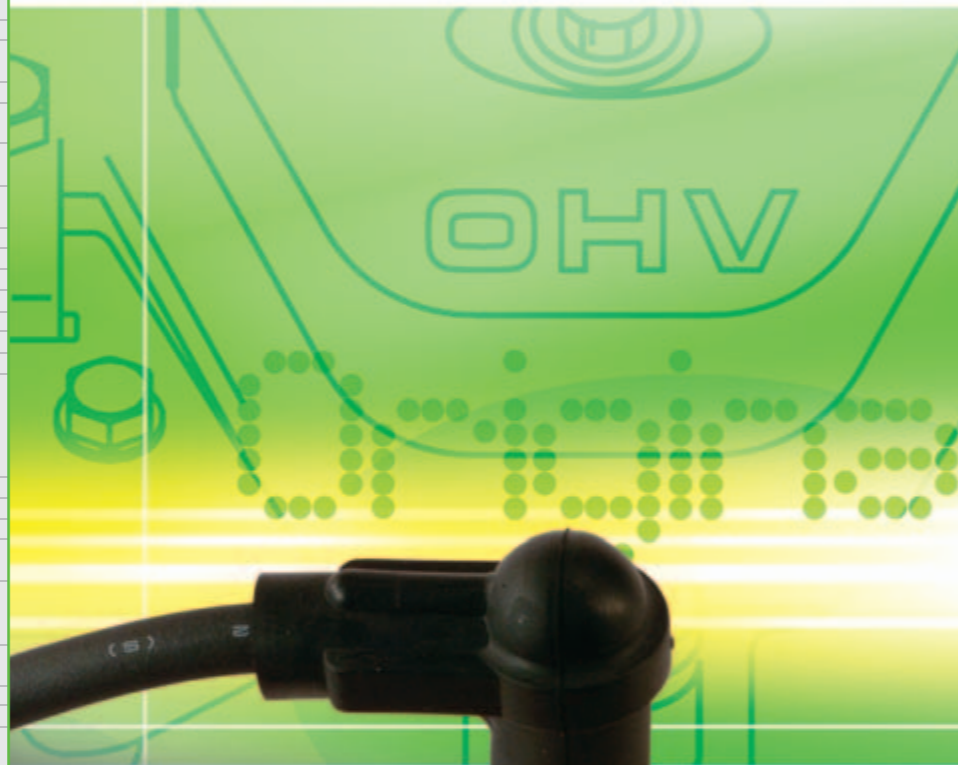

# Aircleaner

| Engine model  | REF. | Aircleaner     | Outer filter  | Dimensions |       |        | Material / shape              |
|---|------|----------------|---------------|------------|-------|--------|-------------------------------|
|   |      |                |               | Long.      | Width | Height |                               |
| G 100K1, G100K2   | 1    | 17211-896-000  |               | 94         | 76    | 25     | urethane, rectangle           |
| G 150, G 200  | 2    | 17211-883-010  |               | 120        | 120   | 40     | urethane, round               |
| G 150K1, G 200K1  | 3    | 17211-883-W21  | 17218-883-W21 | 178        | 89    | 29     | paper, rectangle              |
| GC 135/160/190, GS 160/190, GCV 135/160/190, GSV 160/190                              | 3    | 17211-ZL8-023  |               | 133        | 115   | 21     | paper, rectangle              |
| GX 25, GX 25T, GX 25N, GX 25NT, GX 35   | 4    | 17211-Z0H-000  |               | 76         | 83    | 20     | urethane, +/- oval            |
| GX 25T, GX 25N, ( type T3, TZ3, TZR3 )  | 4    | 17211-Z0H-800  |               | 76         | 83    | 20     | urethane, +/- oval            |
| GX 35T, GX 35N, GX 35NT   | 4    | 17211-Z0Z-000  |               | 100        | 70    | 25     | urethane, +/- oval            |
| GX 22, GX 31  | 5    | 17211-ZM3-000  |               | 72         | 72    | 20     | urethane, round               |
| GXH 50, GXH 50U, GXV 50, GXV 50U  | 1    | 17211-ZM7-000  |               | 89         | 89    | 12     | urethane, square              |
| GX 100 STD, GX 100 TAMP, GX 100U  | 3    | 17211-ZL8-023  | 17218-Z0D-000 | 133        | 115   | 21     | paper, rectangle              |
| GX 120K1, GX 120T1, GX 120U1, GX 120UT1   | 6    | 17210-ZE0-505* | 17218-ZE0-505 | 102        | 74    | 52     | paper,oval(out filt.urethane) |
| GX 160K1, GX 160T1, GX 160H1, GX 160U1, GX 160UT1, GX 200, GX 200T, GX 200U, GX 200UT | 6    | 17210-ZE1-505* | 17218-ZE1-507 | 102        | 74    | 71     | paper,oval(out filt.urethane) |
| GX 240K1, GX 270, GX 240U1, GX 270U   | 6    | 17210-ZE2-515* | 17218-ZE2-505 | 155        | 121   | 40     | paper,oval(out filt.urethane) |
| GX 340K1, GX 390K1, GX 390T1, GX 340U1, GX 390U1, GX 390UT1                           | 6    | 17210-ZE3-505* | 17218-ZE3-505 | 112        | 97    | 92     | paper,oval(out filt.urethane) |
| GX 360K1  | 6    | 17210-ZA0-506  | 17218-ZA0-506 | 165        | 105   | 40     | paper,oval(out filt.urethane) |
| GX 640  | 7    | 06172-ZG8-L20  | 17218-ZG8-000 | 186        | 174   | 34     | paper, rectangle              |
| GX 610, GX 620, GXV 610, GXV 620  | 7    | 17010-ZJ1-000  | 17218-ZJ1-000 | 238        | 183   | 32     | paper, rectangle              |
| GX 610K1 / U1, GX 620K1 / U1, GX 670 / U, GXV 610K1, GXV 620K1 / U1, GXV 670 / U      | 8    | 17210-ZJ1-842  | 17218-ZJ1-840 | 225        | 167   | 30     | paper, rectangle              |
| GV 100K1  | 9    | 17211-ZG1-700  |               | 130        | 75    | 25     | urethane, +/-rectangle        |
| GV 100K2  | 9    | 17211-ZL1-000  |               | 120        | 70    | 25     | urethane, +/-rectangle        |
| GCV 520, GCV 530, GXV 520, GXV 530, GXV 530U  | 8    | 17211-Z0A-013  | 17218-Z0A-810 | 215        | 20    | 22     | paper, rectangle              |
| GXV 120   | 6    | 17210-ZE6-505* | 17218-ZE6-505 | 190        | 62    | 50     | paper,oval(out filt.urethane) |
| GXV 140   | 7    | 17211-ZG9-800  | 17218-ZG9-800 | 137        | 61    | 25     | paper, rectangle              |
| GXV 160   | 6    | 17210-ZE7-505* | 17218-ZE6-505 | 190        | 63    | 45     | paper,oval(out filt.urethane) |
| GXV 160K1, GXV 160H2, GXV 160UH2  | 6    | 17211-ZE7-W03* | 17218-ZE7-W02 | 180        | 62    | 50     | paper,oval(out filt.urethane) |
| GXV 270K1, GXV 340K1/K2   | 6    | 17210-ZF5-505  | 17218-ZF5-505 | 124        | 60    | 87     | paper, oval                   |
| GXV 340K2, GXV 340T2 / UT2, GXV390K1, GXV 390T1 / UT1                                 | 6    | 17211-ZF5-V01  | 17218-ZF5-V00 | 124        | 60    | 87     | paper, oval                   |
| GX 440U   | 6    | 17210-Z2E-000  |               | 102        | 74    | 71     | paper,oval(out filt.urethane) |

\* = aircleaner + outer filter

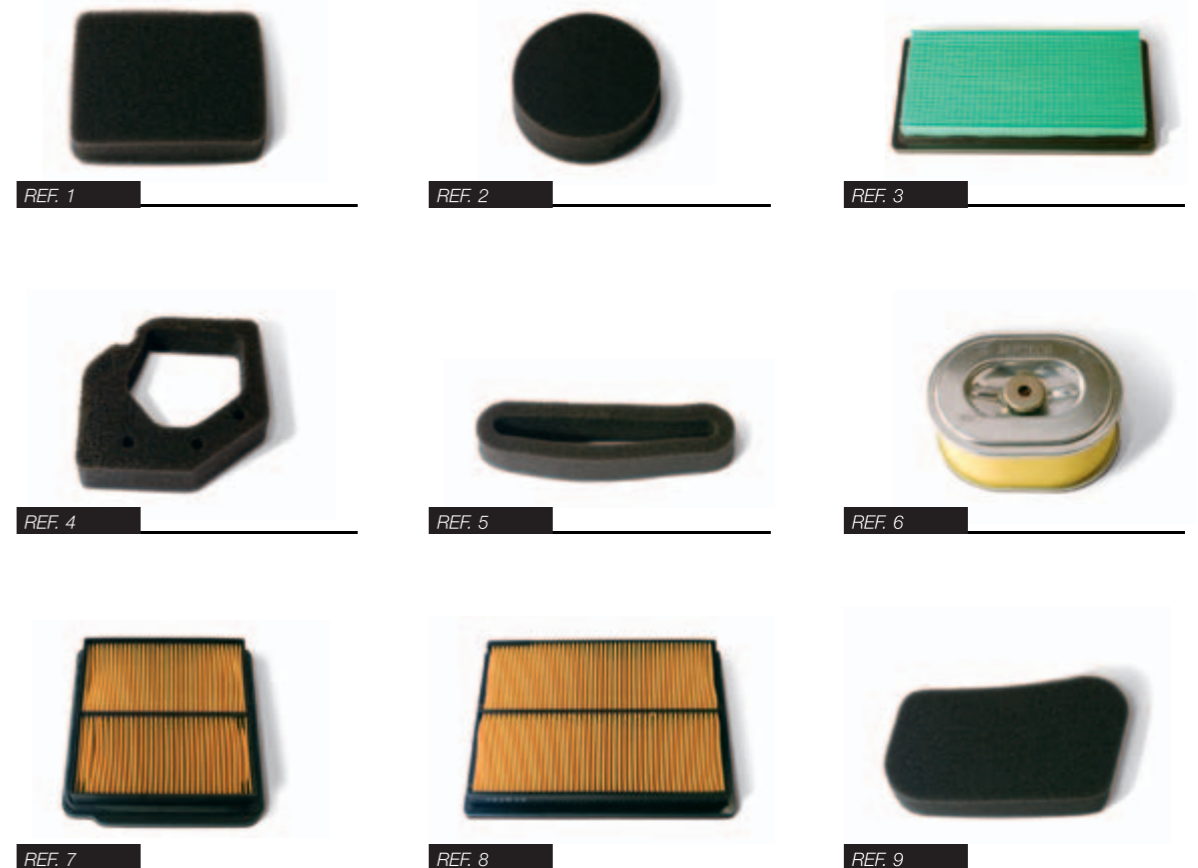

# Oilfilter



Oilfilter

| Engine model   | Oilfilter     | Ø  | Height | Material    |
|--|---------------|----|--------|-------------|
| GXV 340K2, GXV 610, GXV 610K1 / U, GXV 620, GXV 620K1 / U1, GXV 670 / U, GX 610, GX 610K1 /U1, GX 620K1 / U1, GX 670 / U | 15400-ZJ1-004 | 83 | 82     | metal, cyl. |
| GX 360K1, GCV 520, GCV 530, GXV 520, GXV 530   | 15400-PFB-014 | 65 | 65     | metal, cyl. |
| GX 640   | 15400-PFB-007 | 69 | 72     | metal, cyl. |
| GXV 340K1, GXV 390   | 15400-RBA-F01 | 65 | 85     | metal, cyl. |



Fuel strainer

# Fuel strainer

| Engine model  | Fuel strainer | Small Ø | Big Ø | Height | Material |
|---|---------------|---------|-------|--------|----------|
| GCV 530, GC 135, GC 160, GC 190, GXV 520, GXV 530 / U   | 16910-ZV4-015 | 22      | 29    | 67     | plastic  |
| GX 100, GX 120K1 / T1, GX 160K1 / T1, GX 200 / T1 / U / UT, GX 240K1 / U1, GX 270 / U, GX 360K1, GX 390K1 / T1 / U1 / UT1   | 16910-GB2-005 | 23      | 30    | 53     | plastic  |
| GXV 340K1, GXV 340K2, GXV 390K1, GXV 610, GXV 610K1, GXV 620, GXV 620K1, GXV 670, GX 360K1, GX 610, GX 610K1, GX 620, GX 620K1, GX 670, G 100K1, G 100K2, GXV 270K1 | 16910-ZE8-015 | 22      | 29    | 65     | plastic  |
| G 100K2   | 16910-ZG0-U02 | 22      | 29    | 64     | plastic  |
| GXV 160H2 / UH2   | 16952-ZA8-800 | 23      | 30    | 53     | plastic  |
| GXV 390T1 / UT1   | 16952-ZE6-000 | 23      | 30    | 53     | plastic  |

# Spark plugs

| Engine model | ND              | NGK             |
|--------------|-----------------|-----------------|
| G100K1       | 98073-54754     | 98073-54744     |
| G100K2       |                 | 9873-54776      |
| G150         | 98076-54720     | 98076-54716     |
| G150         | 98076-54821 CDI | 98076-54911 CDI |
| G150K1       | 98076-54780     | 98076-54710     |
| G200         | 98076-54720     | 98076-54716     |
| G200         | 98076-54921 CDI | 98076-54914 CDI |
| G200K1       | 98076-54780     | 98076-54710     |
| GC135        |                 | 98079-56846     |
| GC160        |                 | 98079-56846     |
| GC190        |                 | 98079-56846     |
| GS160        |                 | 98079-56846     |
| GS190        |                 | 98079-56846     |
| GX22         | 98056-55757     | 98056-55777     |
| GX31         |                 | 98056-55777     |
| GX25         |                 | 31915-20H-003   |
| GX25T        |                 | 31915-20H-003   |
| GX25N        |                 | 31915-20H-003   |
| GX25NT       |                 | 31915-20H-003   |
| GX35         |                 | 31915-20H-003   |
| GX35T        |                 | 31915-20H-003   |
| GX35N        |                 | 31915-20H-003   |
| GX35NT       |                 | 31915-20H-003   |
| GXH50        |                 | 98056-55777     |
| GXH50U       | 98056-55757     | 9805655777      |
| GX100STD     | 98056-55757     | 98056-55777     |
| GX100TAMP    | 98056-55757     | 98056-55777     |
| GX100U       | 98056-55757     | 98056-55777     |
| GX120K1      | 98079-56855     | 98079-56846     |
| GX120U1      | 98079-56855     | 98079-56846     |
| GX120T1      | 98079-56855     | 98079-56846     |
| GX120UT1     | 98079-56855     | 98079-56846     |
| GX160K1      | 98079-56855     | 98079-56846     |
| GX160T1      | 98079-56855     | 98079-56846     |
| GX160H1      | 98079-56855     | 98079-56846     |
| GX160U1      | 98079-56855     | 98079-56846     |
| GX160UT1     | 98079-56855     | 98079-56846     |
| GX200        | 98079-56855     | 98079-56846     |
| GX200U       | 98079-56855     | 98079-56846     |
| GX200T       | 98079-56855     | 98079-56846     |
| GX200UT      | 98079-56855     | 98079-56846     |
| GX240K1      | 98079-56855     | 98079-56846     |
| GX240U1      | 98079-56855     | 98079-56846     |
| GX270        | 98079-56855     | 98079-56846     |
| GX270U       | 98079-56855     | 98079-56846     |
| GX340K1      | 98079-56855     | 98079-56846     |
| GX340U1      | 98079-56855     | 98079-56846     |
| GX390K1      | 98079-56855     | 98079-56846     |
| GX390U1      | 98079-56855     | 98079-56846     |
| GX390T1      | 98079-56855     | 98079-56846     |
| GX390UT1     | 98079-56855     | 98079-56846     |
| GX360K1      |                 | 98076-54747     |
| GX340K1      | 98079-55155     | 98079-55145     |
| GX440IU      | 98079-5785C     | 98079-5787C     |
| GX610        | 98079-56855     | 98079-56846     |
| GX620        | 98079-56855     | 98079-56846     |
| GX610K1      | 98079-5585V     | 98079-5587V     |
| GX610U1      | 98079-5585V     | 98079-5587V     |
| GX620K1      | 98079-5585V     | 98079-5587V     |
| GX620U1      | 98079-5585V     | 98079-5587V     |
| GX670        | 98079-5585V     | 98079-5587V     |
| GX670U       | 98079-5585V     | 98079-5587V     |
| GV100K1      | 98073-54754     | 98073-54744     |
| GV100K2      |                 | 98073-54776     |
| GCV135       |                 | 98079-56846     |
| GCV160       |                 | 98079-56846     |
| GCV190       |                 | 98079-56846     |
| GCV520       | 98079-55855     | 98079-56846     |
| GCV530       | 98079-55855     | 98079-56846     |
| GSV160       |                 | 98079-56846     |
| GSV190       |                 | 98079-56846     |
| GXV50        | 98056-55757     | 98056-55777     |
| GXV50U       | 98056-55757     | 9805655777      |
| GXV120       | 98079-55855     | 98079-55846     |
| GXV140       |                 | 98079-55846     |
| GXV160       | 98079-55855     | 98079-55846     |
| GXV160K1     | 98079-55855     | 98079-55846     |
| GXV160H2     | 98079-55855     | 98079-55846     |
| GXV160UH2    | 98079-55855     | 98079-55846     |
| GXV270K1     | 98079-55855     | 98079-55846     |
| GXV340K1     | 98079-55855     | 98079-55846     |
| GXV340K2     |                 | 98079-55846     |
| GXV340T2     |                 | 98079-55846     |
| GXV340UT2    |                 | 98079-55846     |
| GXV390K1     |                 | 98079-55846     |
| GXV390T1     |                 | 98079-55846     |
| GXV390UT1    |                 | 98079-55846     |
| GXV520       | 98079-55855     | 98079-55846     |
| GXV530       | 98079-55855     | 98079-55846     |
| GXV530U      | 98079-55855     | 98079-55846     |
| GXV610       |                 | 98079-55846     |
| GXV620       |                 | 98079-55846     |
| GXV610K1     | 98079-5585V     | 98079-5587V     |
| GXV620K1     | 98079-5585V     | 98079-5587V     |
| GXV620U1     | 98079-5585V     | 98079-5587V     |
| GXV670       | 98079-5585V     | 98079-5587V     |
| GXV670U      | 98079-5585V     | 98079-5587V     |



Spark plug

# Oil

| Parts reference | Quantity  |
|-----------------|-----------|
| 08221-888-060HE | 1 x 0,6L  |
| 08221-888-100HE | 1 x 1L    |
| 08221-888-060MP | 24 x 0,6L |
| 08221-888-100MP | 24 x 1L   |



# Service Kit

| Parts reference | Quantity |
|-----------------|----------|
| 06211-ZL8-000   | 1        |
| 06211-ZL8-000MP | 12 x 1   |



# Accessoires

|  |                                |       |
|--|--------------------------------|-------|
| Cable holder   | GX 10 000 000                  | p. 14 |
| 11 liter fuel tank                                       | 17500-GX1-11L                  | p. 15 |
| 18 liter fuel tank                                       | 17500-GX1-18L                  | p. 15 |
| Oil dipstick (205 mm)                                    | GX 120-K10-05                  | p. 16 |
| Oil dipstick (225 mm)                                    | GX 160-K10-06                  | p. 17 |
| Oil dipstick (370 mm)                                    | GX 160-K10-26                  | p. 17 |
| Oil dipstick (255 mm)                                    | GX 340-390-K18 / GX 270-000-07 | p. 18 |
| Oil dipstick   | GX 390-K10-01                  | p. 19 |
| En-guard (plastic type) no deflector                     | 06185-ZF6-W400                 | p. 20 |
| En-guard (plastic type) with deflector                   | 06185-ZF6-W500                 | p. 21 |
| En-guard (plastic type) no deflector                     | 06185-ZH8-W400                 | p. 22 |
| En-guard (plastic type) with deflector                   | 06185-ZH8-W500                 | p. 23 |
| En-guard (metal type) no deflector                       | 06185-ZH8-W600                 | p. 24 |
| En-guard no deflector                                    | 06185-ZK9-W400                 | p. 25 |
| En-muffler guard (plastic type) with deflector           | 06185-ZK9-W500                 | p. 26 |
| Universal muffler for v-twin engine                      | 06183-ZJ1-BOSU                 | p. 27 |
| Top mount muffler  | 06183-ZJ1-BOSL                 | p. 27 |
| Top mount muffler  | 06183-ZJ1-BOSR                 | p. 28 |
| Heat shield  | 18434-ZJ1-BOS                  | p. 28 |
| Deflector (90°)  | 18431-ZH8-BOS                  | p. 29 |
| Exhaust flange   | GX620-000001                   | p. 29 |
| Exhaust pipe   | 18331-Z0A-SET                  | p. 30 |
| Deflector (long type)                                    | 18431-ZH8-W500                 | p. 30 |
| Deflector (short type)                                   | GX200-000-00                   | p. 31 |
| Low noise muffler  | 18310-ZB8-SIL                  | p. 31 |
| Pipe comp., ex. (high-r)                                 | 18330-ZJ1-841                  | p. 32 |
| Pipe comp., ex. (high-l)                                 | 18330-ZJ1-851                  | p. 32 |
| Pipe comp., ex. (side-l)                                 | 18330-ZJ1-861                  | p. 33 |
| Spark arrester   | 18355-ZN1-003                  | p. 33 |
| Joint assy., connecting tube                             | 17415-ZJ1-840                  | p. 34 |
| Valve, oil shut-off                                      | 15558-ZJ1-010AH                | p. 34 |
| Switch, oil pressure                                     | 37240-ZG3-E01                  | p. 35 |
| Dual function hour & tachometer                          | 08174-ZL8-000HE                | p. 35 |
| Screen grid (p.t.o.)                                     | 28454-ZJ1-KIT                  | p. 36 |
| Shaft, fr. p.t.o.  | 23311-ZJ1-KIT                  | p. 36 |
| Switch assy, engine stop                                 | 35120-Z2E-003                  | p. 37 |
| Switch assy combination (remote, with fuse)              | 35100-Z2E-003                  | p. 37 |
| Switch assy combination (remote, w/o fuse)               | 35100-Z2E-X010                 | p. 38 |
| Volume assy, speed                                       | 35570-Z2E-004                  | p. 38 |
| Extension harness, for combination switch assy with fuse | 35105-Z2E-X000                 | p. 39 |
| Extension harness assy, subwire (6p & 3 terminals)       | 32105-Z2E-X000                 | p. 39 |
| Ext. harness assy, subwire (6p & 6p)                     | 32105-Z2E-X010                 | p. 40 |
| Coupler, short (switch 1 function)                       | 32130-Z2E-0001                 | p. 40 |
| 6p, gray (volume switch), male                           | 6187-6809                      | p. 41 |
| 6p, gray (volume switch), female                         | 6180-6187                      | p. 41 |
| 4p, blue (communication port), male                      | 6187-4445                      | p. 42 |
| 4p, blue (communication port), female                    | 6180-4185                      | p. 42 |
| Dummy plug   | 7160-9465                      | p. 43 |
| Wire seal  | 7160-8234                      | p. 43 |
| Terminal, male   | 1500-0105                      | p. 43 |
| Terminal, female   | 1500-0106                      | p. 43 |
| 2p coupler kit (female)                                  | 9845F-00002-00                 | p. 44 |
| 2p coupler kit (male)                                    | 9835F-10002-00                 | p. 44 |
| Str govern (overwrite kit)                               | IGXST-KIT                      | p. 45 |
| V-twin winter kit  | 06192-ZJ1-800                  | p. 46 |

# Cable holder

| Remote throttle operation for  | Partnumber    | Packing       |
|--|---------------|---------------|
| GX 120K1, 120T1 / 160K1, 160T1 / 200, 200T / 240K1 / 270, 270T / 340K1 / 390K1, 390T1 / GX 610K1 / 620K1 / 670 | GX 10 000 000 | 50 pieces/set |

| REF. | Component name | QTY |
|------|----------------|-----|
| 1    | screw (M4 x 8) | 1   |
| 2    | cable holder   | 1   |
| 3    | E-ring         | 1   |

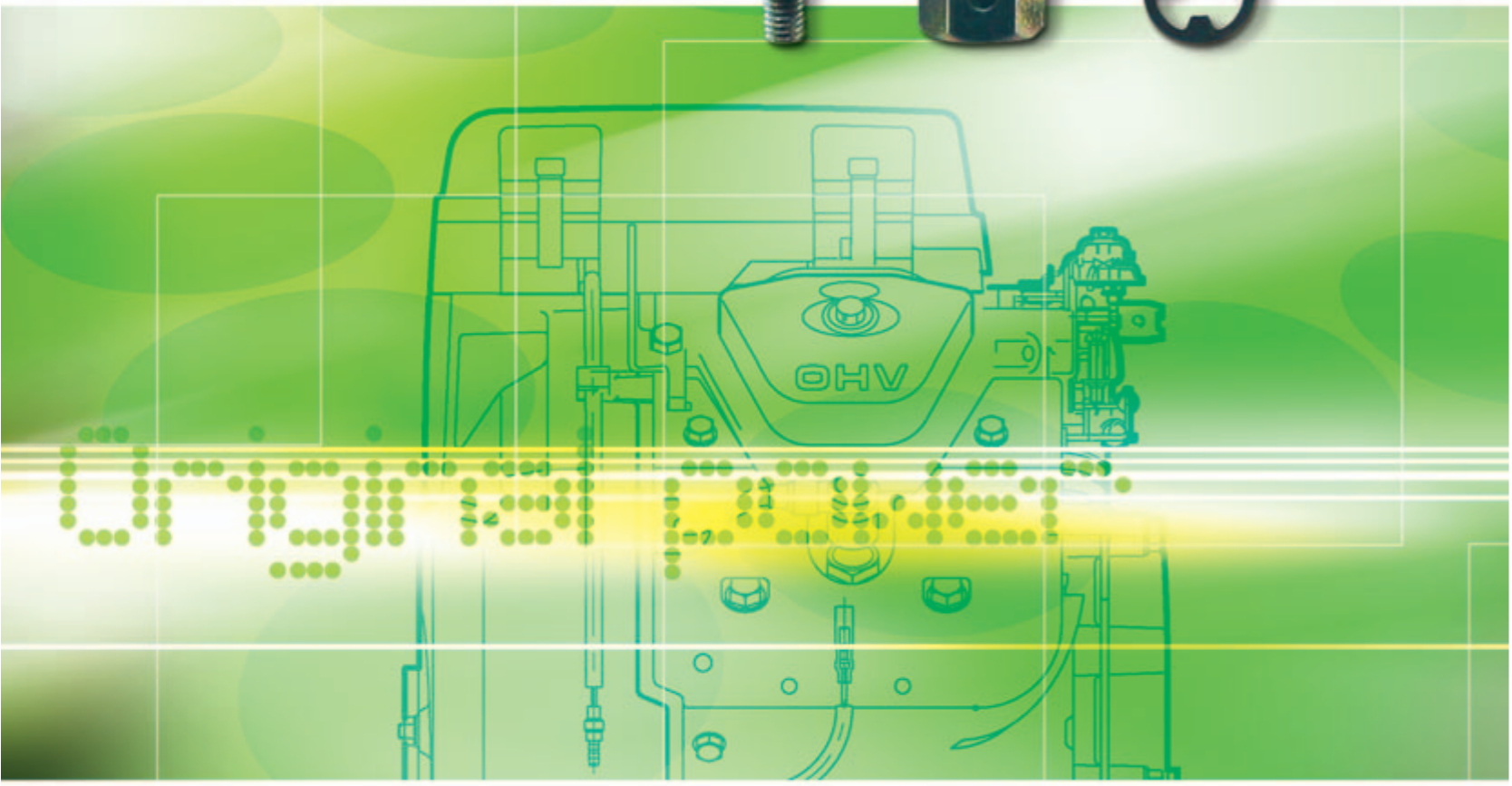
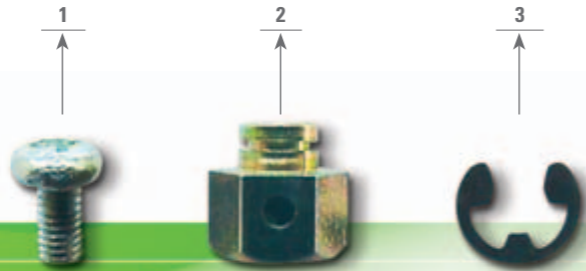

# 11 liter fuel tank

| Partnumber    | Packing     |
|---------------|-------------|
| 17500-GX1-11L | 1 piece/set |

| REF. | Component name        | QTY |
|------|-----------------------|-----|
| 1    | fuel tank comp.       | 1   |
| 2    | fuel filler cap comp. | 1   |
| 3    | fuel meter assy.      | 1   |
| 4    | flat screw 5x10       | 2   |
| 5    | fuel cock assy.       | 1   |



Height = 140 mm  
(measured without fuel filler cap comp. and fuel cock assy.)

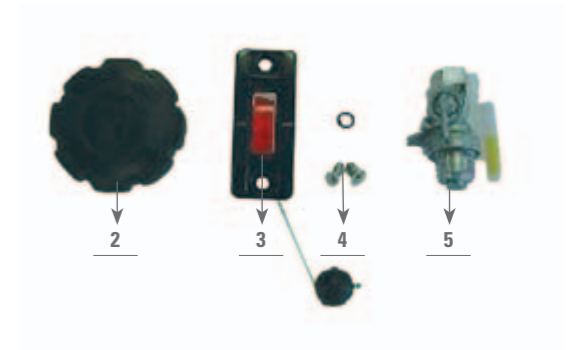

# 18 liter fuel tank

| Partnumber    | Packing     |
|---------------|-------------|
| 17500-GX1-18L | 1 piece/set |

| REF. | Component name        | QTY |
|------|-----------------------|-----|
| 1    | fuel tank comp.       | 1   |
| 2    | fuel filler cap comp. | 1   |
| 3    | fuel meter assy.      | 1   |
| 4    | flat screw 5x10       | 2   |
| 5    | fuel cock assy.       | 1   |



Height = 135 mm  
(measured without fuel filler cap comp. and fuel cock assy.)

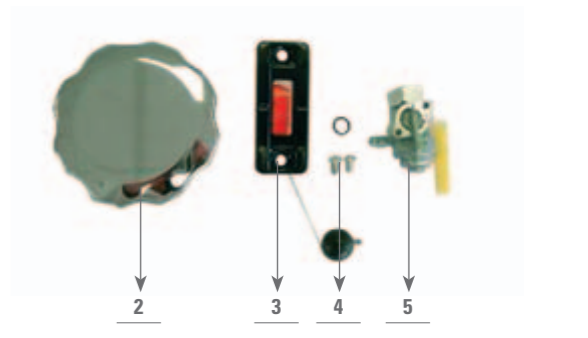



# Oil dipstick (205 mm)

| Extension of oil level gauge for | Partnumber    | Packing     |
|----------------------------------|---------------|-------------|
| GX 120K1, 120T1                  | GX 120-K10-05 | 1 piece/set |

| REF. | Component name     | QTY |
|------|--------------------|-----|
| 1    | oil level dipstick | 1   |
| 2    | screw              | 1   |
| 3    | collar             | 1   |
| 4    | stay               | 1   |

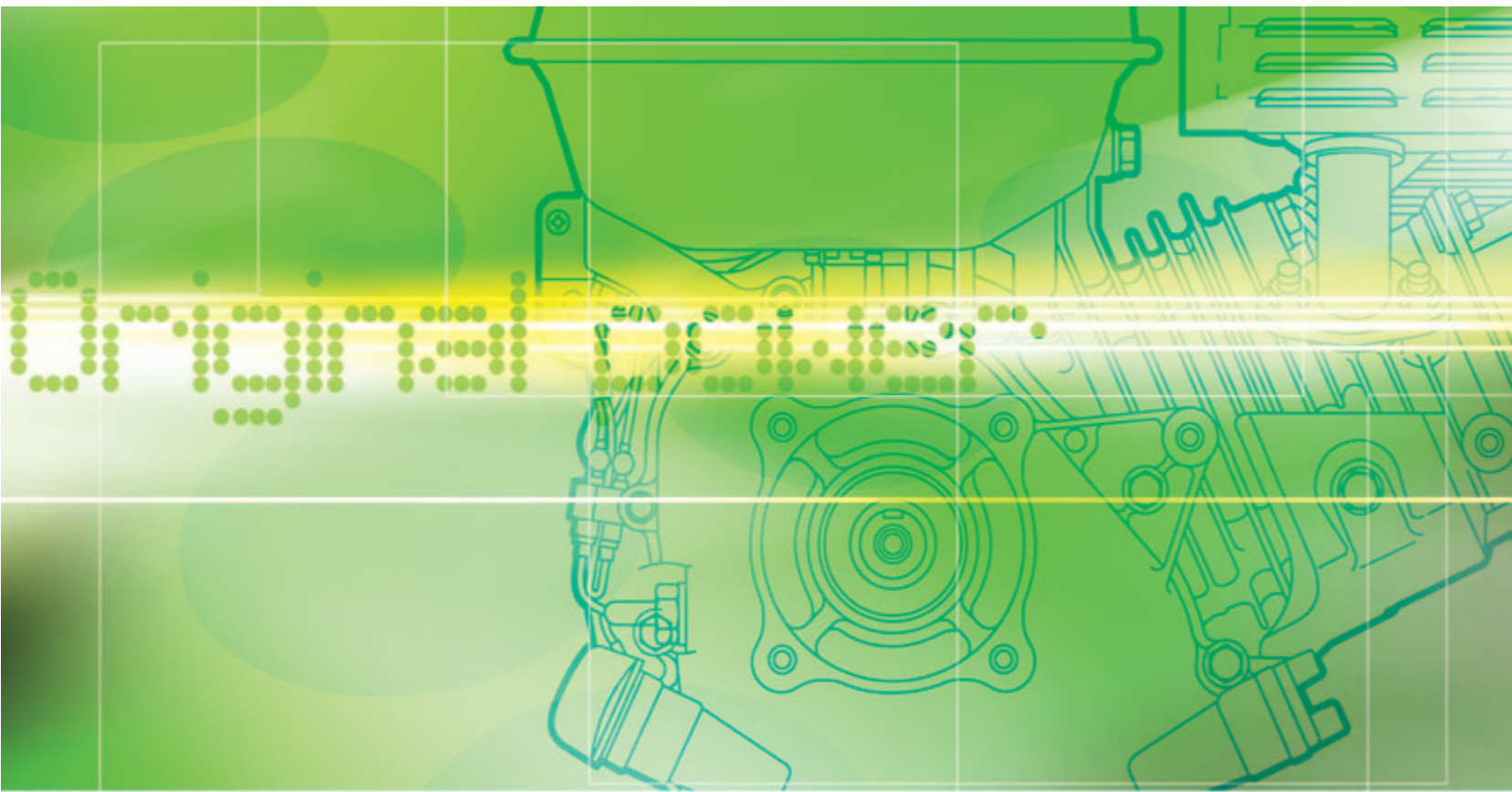
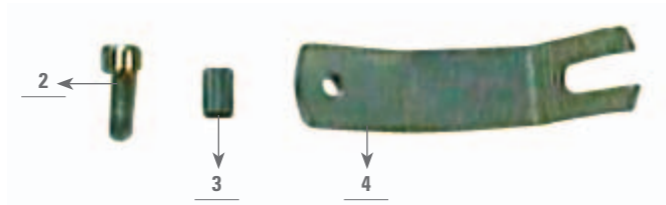

# Oil dipstick (225 mm)

| Extension of oil level gauge for | Partnumber    | Packing     |
|----------------------------------|---------------|-------------|
| GX 160K1, 160T1 / GX200, 200T    | GX 160-K10-06 | 1 piece/set |

| REF. | Component name     | QTY |
|------|--------------------|-----|
| 1    | oil level dipstick | 1   |
| 2    | screw              | 1   |
| 3    | collar             | 1   |
| 4    | stay               | 1   |

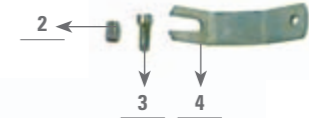

# Oil dipstick (long)

| Extension of oil level gauge for  | Partnumber    | Packing     |
|---|---------------|-------------|
| GX 120K1, 120T1 / GX 160K1, 160T1 / GX 200, 200T / GX 240K1 / GX 270, 270T / GX 340K1 / GX 390K1, 390T1 | GX 160-K10-26 | 1 piece/set |

| REF. | Component name     | QTY |
|------|--------------------|-----|
| 1    | oil level dipstick | 1   |
| 2    | screw              | 1   |
| 3    | collar             | 1   |
| 4    | stay               | 1   |

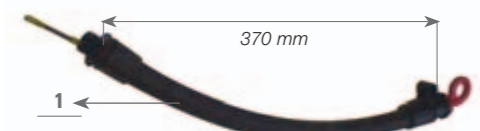
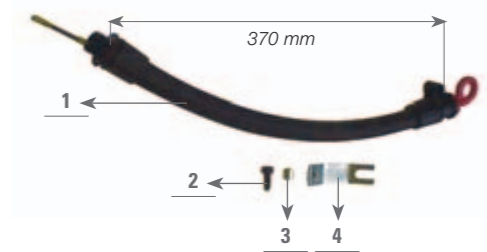

Mounted on front support tank  
Applicable for GX 120K1, 120T1 / GX 160K1, 160T1 / GX 200, 200T

Applicable for GX 240K1 / GX 270, 270T / GX 340K1 / GX 390K1, 390T1

# Oil dipstick (255 mm)

| Extension of oil level gauge for  | Partnumber                     | Packing     |
|---|--------------------------------|-------------|
| GX 120K1, 120T1 / GX 160K1, 160T1 / GX 200, 200T / GX 240K1 / GX 270, 270T / GX 340K1 / GX 390K1, 390T1 | GX 340-390-K18 / GX 270-000-07 | 1 piece/set |

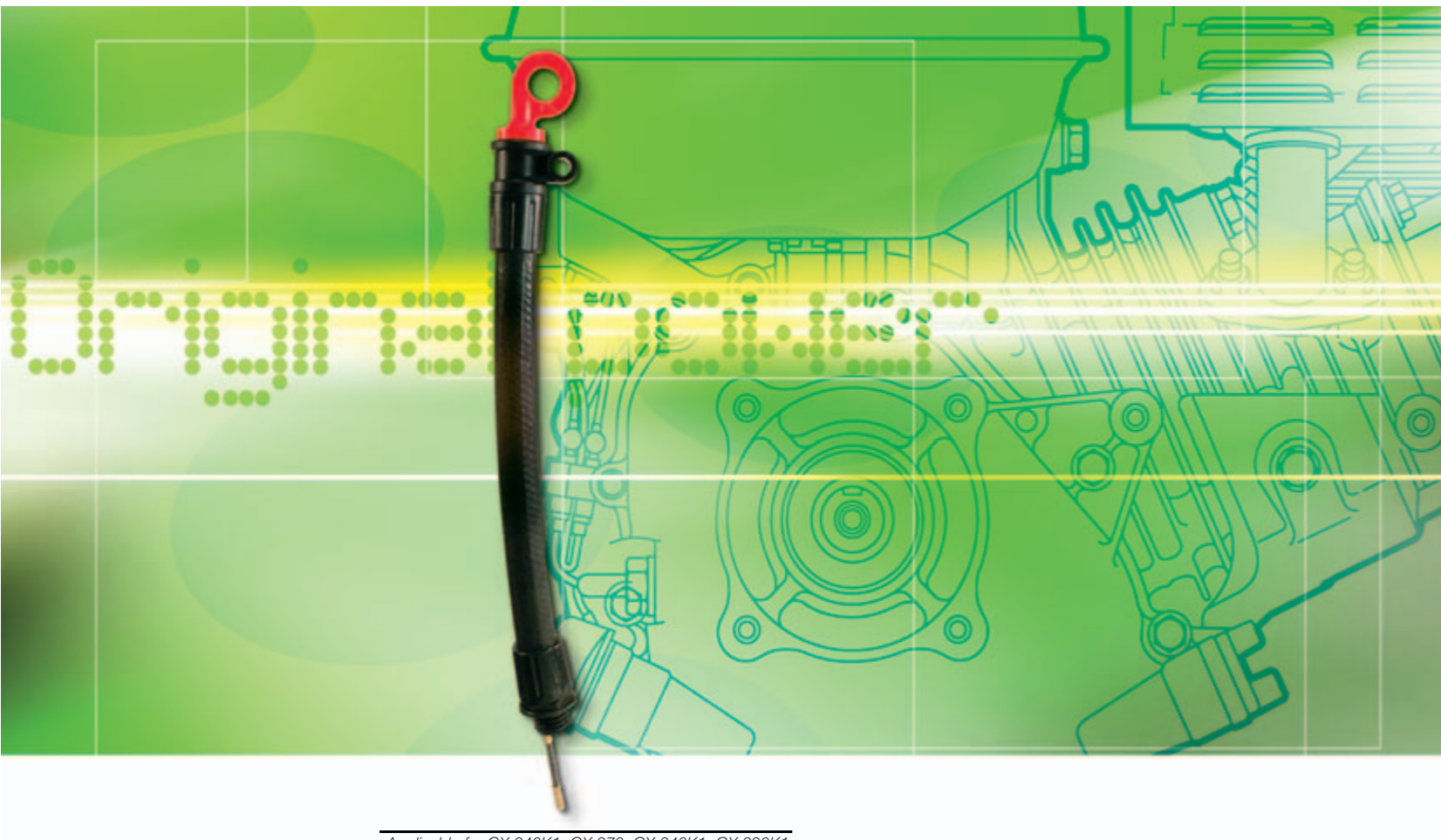
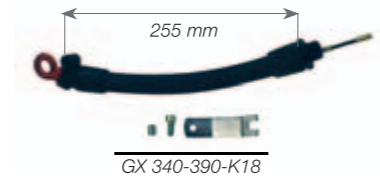

Mounted on front support tank  
Applicable for GX 120K1, 120T1 / GX 160K1, 160T1 / GX 200, 200T



Applicable for GX 240K1 / GX 270, 270T / GX 340K1 / GX 390K1, 390T1

# Oil dipstick

| Extension of oil level gauge for  | Partnumber    | Packing     |
|---|---------------|-------------|
| GX 120K1, 120T1 / 160K1, 160T1 / 200, 200T / 240K1 / 270, 270T / 340K1 / 390K1, 390T1 | GX 390-K10-01 | 1 piece/set |

| REF. | Component name     | QTY |
|------|--------------------|-----|
| 1    | oil level dipstick | 1   |
| 2    | screw              | 1   |
| 3    | collar             | 1   |

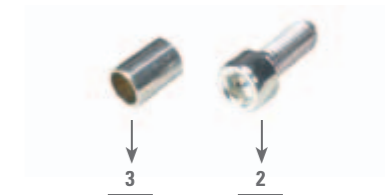

Remark  
Mounting on engine not possible / mounting on frame only

# En-guard (plastic type) no deflector

| Heat protection for   | Partnumber     | Packing     |
|---|----------------|-------------|
| GX 240K1, GX 270, 270T (silent muffler)<br>and GX 340K1 / GX 390K1, 390T1 (std muffler) | 06185-ZF6-W400 | 1 piece/set |

| REF. | Component name           | QTY |
|------|--------------------------|-----|
| 1    | muffler cover comp.      | 1   |
| 2    | rear muffler cover comp. | 1   |
| 3    | muffler cover base comp. | 1   |
| 4    | muffler cover spacer     | 3   |
| 5    | air cleaner case collar  | 2   |
| 6    | hex.nut 5mm              | 3   |
| 7    | plain washer 5mm         | 3   |

| REF. | Component name     | QTY |
|------|--------------------|-----|
| 8    | screw washer 6x20  | 3   |
| 9    | tapping screw 5x25 | 2   |
| 10   | tapping screw 5x8  | 1   |
| 11   | muffler cover stay | 1   |
| 12   | plate set          | 1   |
| 13   | screw washer 5x12  | 1   |
| 14   | spring washer      | 1   |

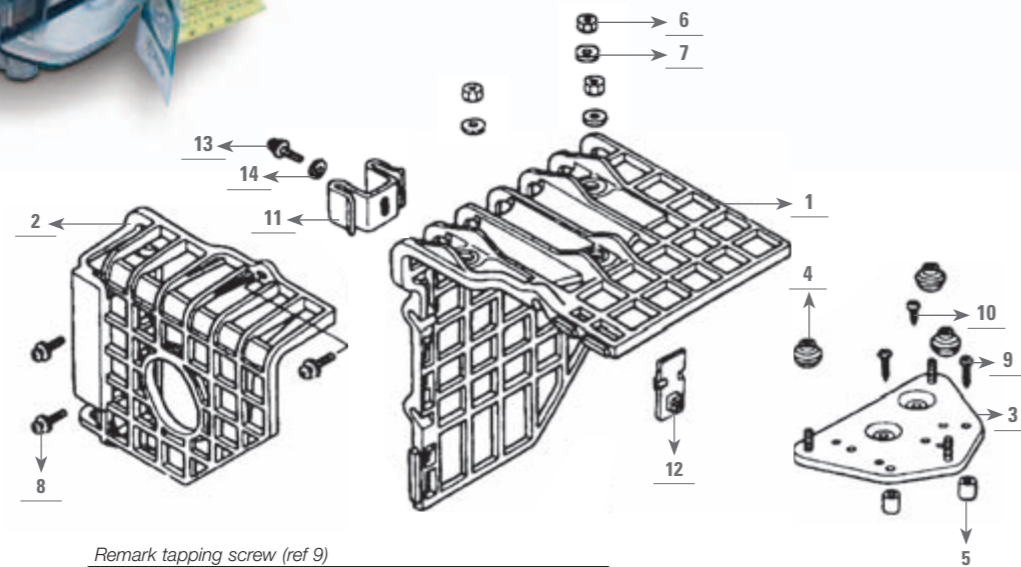
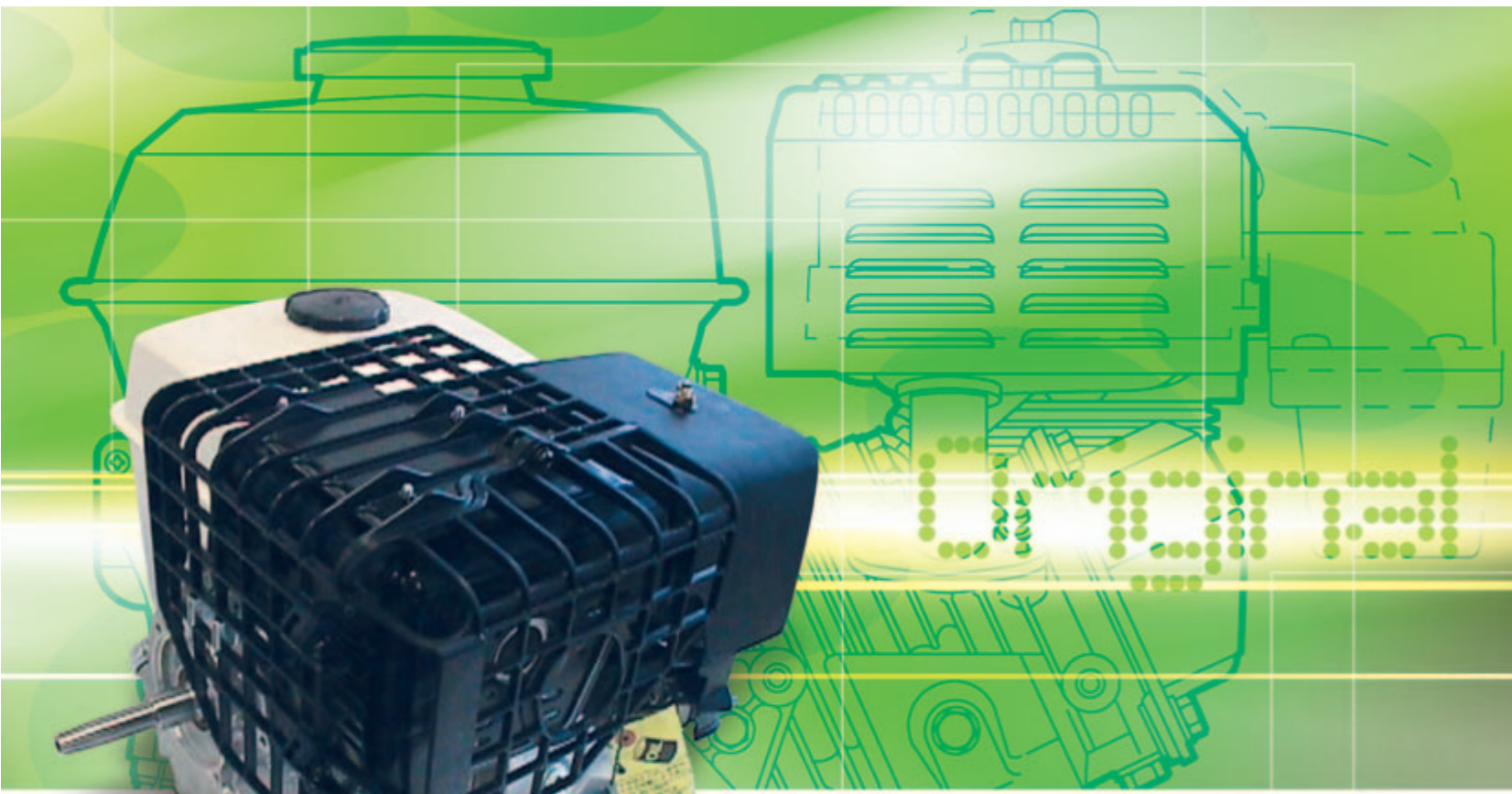

Remark tapping screw (ref 9)  
Must be mounted in holes '4' mentioned on base comp.(ref 3)

# En-guard (plastic type) with deflector

| Heat protection and deflection of exhaust gas for  | Partnumber     | Packing     |
|--|----------------|-------------|
| GAS FOR GX 240K1 / GX 270, 270T (silent muffler)<br>and GX 340K1 / GX 390K1, 390T1 (std muffler) | 06185-ZF6-W500 | 1 piece/set |

| REF. | Component name           | QTY |
|------|--------------------------|-----|
| 1    | muffler cover comp.      | 1   |
| 2    | rear muffler cover comp. | 1   |
| 3    | muffler cover base comp. | 1   |
| 4    | muffler cover spacer     | 3   |
| 5    | air cleaner case collar  | 2   |
| 6    | hex.nut 5mm              | 3   |
| 7    | plain washer 5mm         | 3   |
| 8    | screw washer 6x20        | 3   |

| REF. | Component name     | QTY |
|------|--------------------|-----|
| 9    | tapping screw 5x25 | 2   |
| 10   | tapping screw 5x8  | 1   |
| 11   | muffler cover stay | 1   |
| 12   | plate set          | 1   |
| 13   | screw washer 5x12  | 1   |
| 14   | spring washer      | 1   |
| 15   | deflector          | 1   |
| 16   | tapping screw 4x6  | 2   |

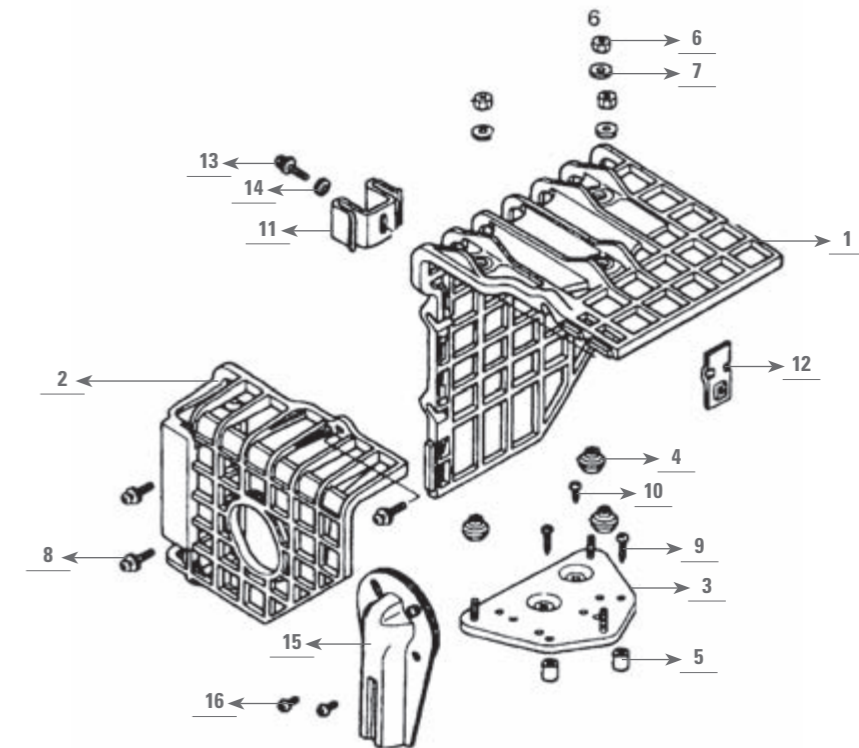
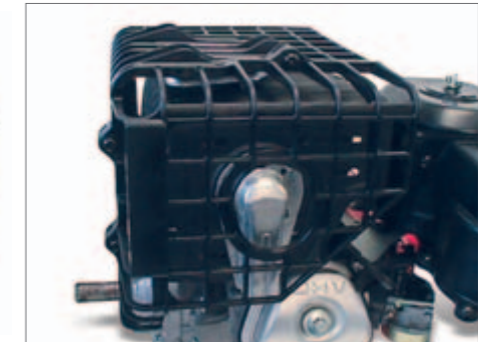
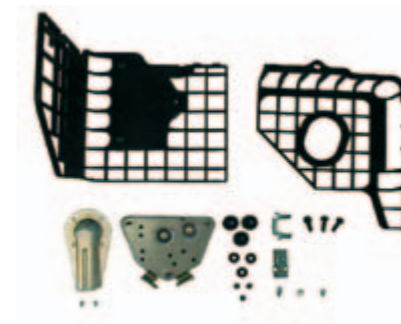

Remark tapping screw (ref 9)  
Must be mounted in holes '4' mentioned on base comp.(ref 3)

# En-guard (plastic type) no deflector

| Heat protection for   | Partnumber     | Packing     |
|---|----------------|-------------|
| GX 120K1, 120T1 / GX 160K1, 160T1 (std and silent muffler) and GX 200, 200T (std muffler) | 06185-ZH8-W400 | 1 piece/set |

| REF. | Component name           | QTY |
|------|--------------------------|-----|
| 1    | muffler cover comp.      | 1   |
| 2    | rear muffler cover comp. | 1   |
| 3    | muffler cover base comp. | 1   |
| 4    | muffler cover spacer     | 3   |
| 5    | air cleaner case collar  | 2   |

| REF. | Component name     | QTY |
|------|--------------------|-----|
| 6    | hex.nut 5mm        | 3   |
| 7    | plain washer 5mm   | 3   |
| 8    | screw washer 6x20  | 3   |
| 9    | tapping screw 5x25 | 2   |
| 10   | tapping screw 5x8  | 1   |

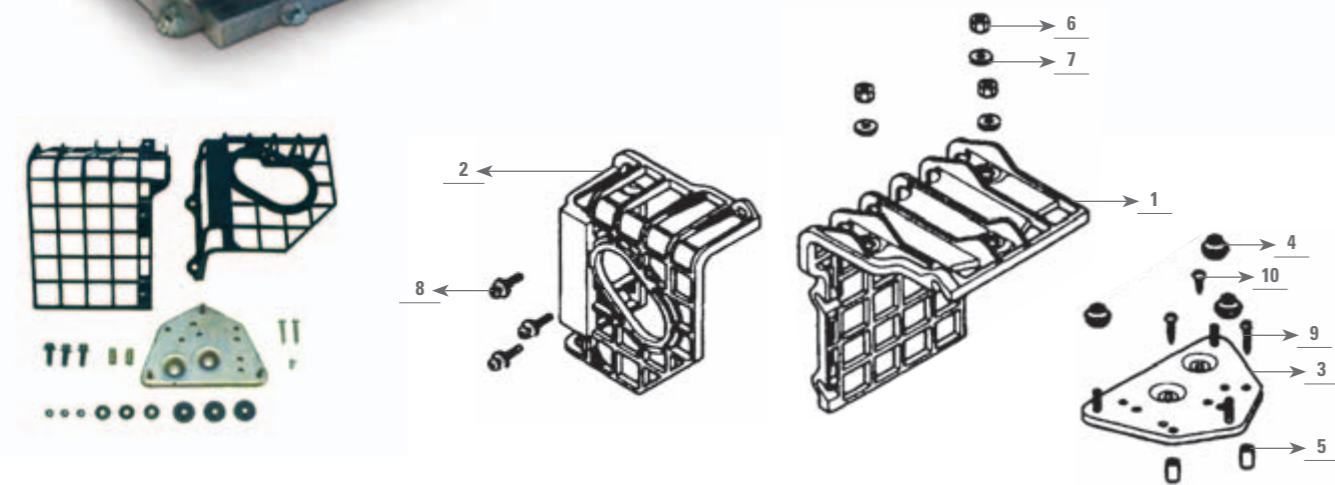
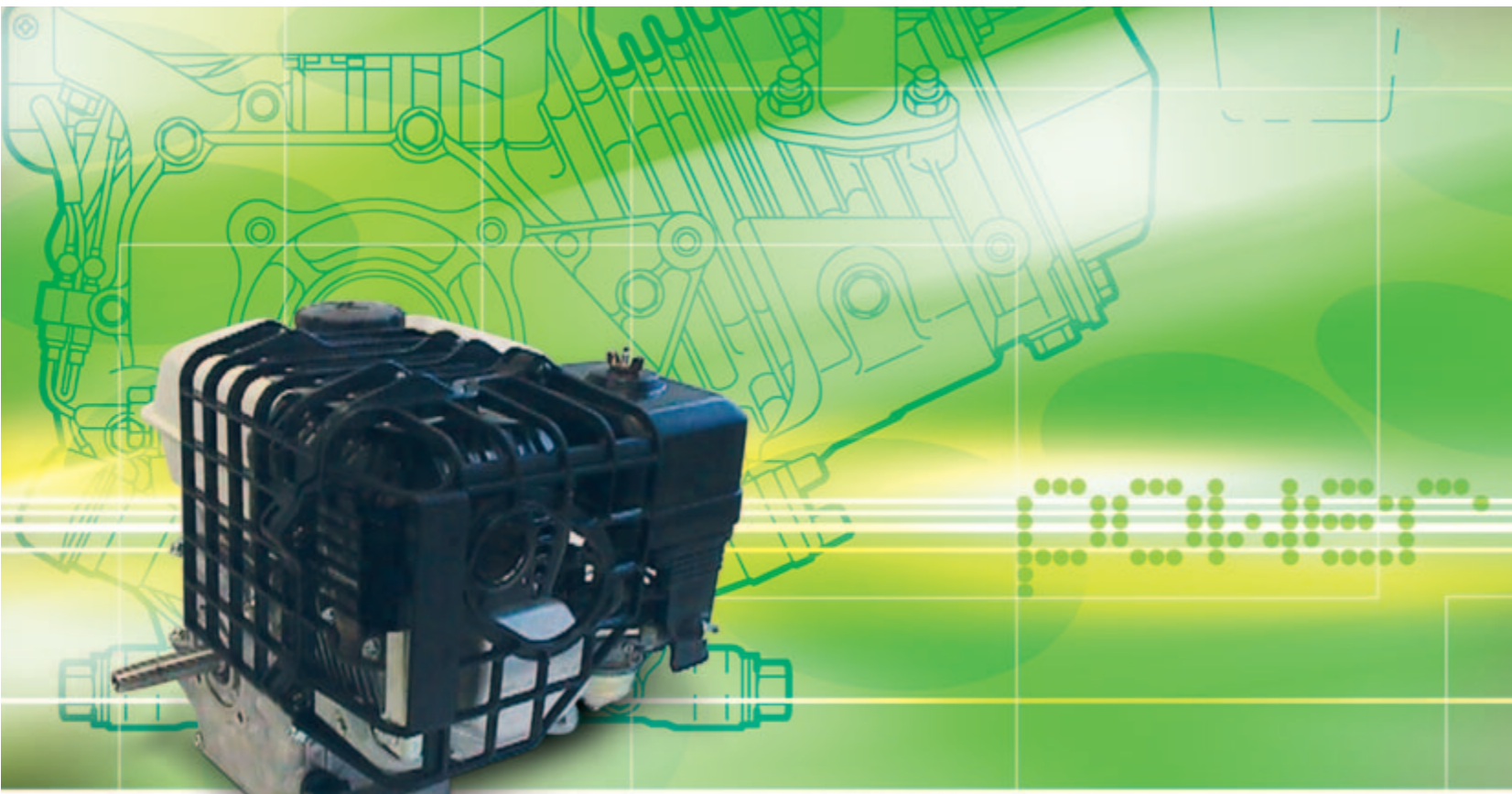

Remark tapping screw (ref 9)  
Must be mounted in holes '2' mentioned on base comp.(ref 3)

# En-guard (plastic type) with deflector

| Heat protection and deflection of exhaust gas for   | Partnumber     | Packing     |
|---|----------------|-------------|
| FOR GX 120K1, 120T1 / GX 160K1, 160T1 (std and silent muffler) and GX 200, 200T (std muffler) | 06185-ZH8-W500 | 1 piece/set |

| REF. | Component name           | QTY |
|------|--------------------------|-----|
| 1    | muffler cover comp.      | 1   |
| 2    | rear muffler cover comp. | 1   |
| 3    | muffler cover base comp. | 1   |
| 4    | muffler cover spacer     | 3   |
| 5    | air cleaner case collar  | 2   |
| 6    | hex.nut 5mm              | 3   |

| REF. | Component name     | QTY |
|------|--------------------|-----|
| 7    | plain washer 5mm   | 3   |
| 8    | screw washer 6x20  | 3   |
| 9    | tapping screw 5x25 | 2   |
| 10   | tapping screw 5x8  | 1   |
| 11   | deflector          | 1   |
| 12   | tapping screw 4x6  | 2   |

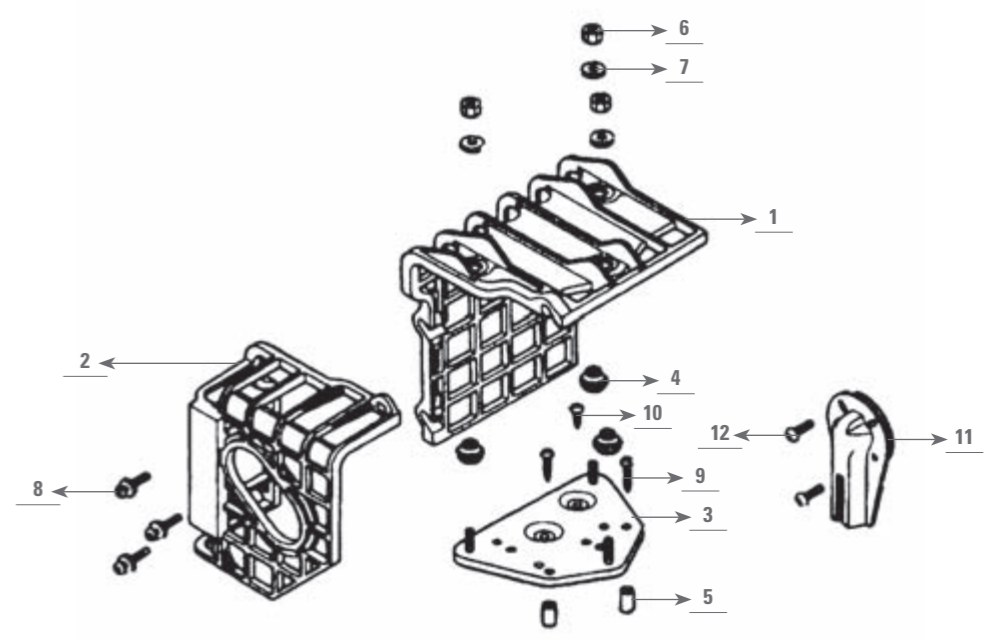
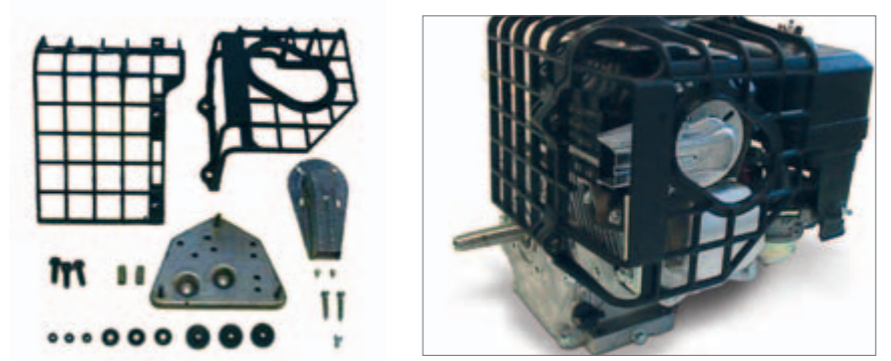

Remark tapping screw (ref 9)  
Must be mounted in holes '2' mentioned on base comp.(ref 3)

# En-guard (metal type) no deflector

| Heat protection for   | Partnumber     | Packing     |
|---|----------------|-------------|
| GX 120K1, 120T1 / GX 160K1, 160T1 tiller (standard muffler) | 06185-ZH8-W600 | 1 piece/set |

| REF. | Component name       | QTY |
|------|----------------------|-----|
| 1    | en-guard             | 1   |
| 2    | screw pan            | 2   |
| 3    | washer ZM5           | 2   |
| 4    | tapping screw 6,3x13 | 1   |
| 5    | washer ZM6           | 1   |

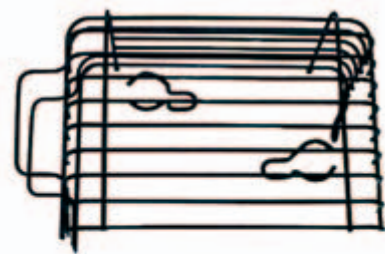

1100  
70

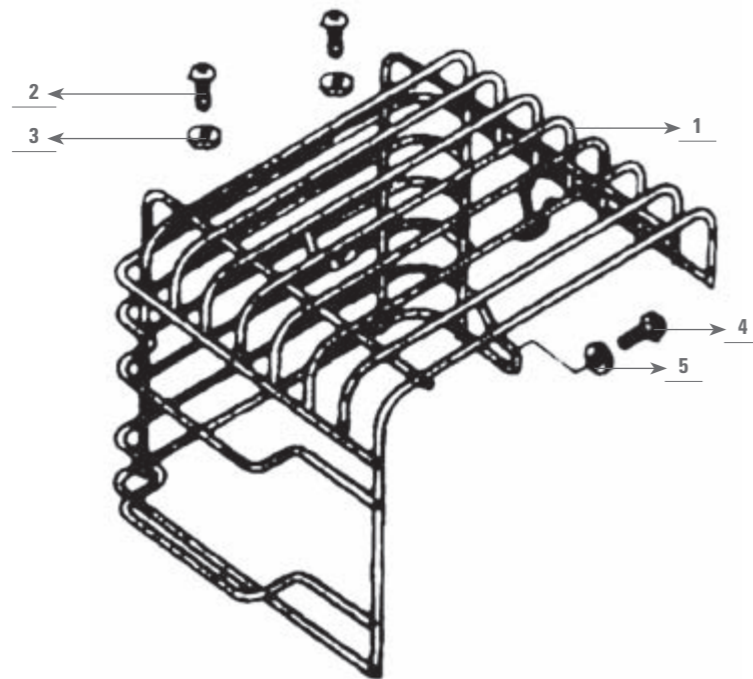

# En-guard no deflector

| Heat protection for                   | Partnumber     | Packing     |
|---------------------------------------|----------------|-------------|
| GX 240K1 / GX 270, 270T (std muffler) | 06185-ZK9-W400 | 1 piece/set |

| REF. | Component name           | QTY |
|------|--------------------------|-----|
| 1    | muffler cover comp.      | 1   |
| 2    | rear muffler cover comp. | 1   |
| 3    | muffler cover base comp. | 1   |
| 4    | muffler cover spacer     | 3   |
| 5    | air cleaner case collar  | 2   |
| 6    | hex.nut 5mm              | 3   |
| 7    | plain washer 5mm         | 3   |

| REF. | Component name     | QTY |
|------|--------------------|-----|
| 8    | screw washer 6x20  | 3   |
| 9    | tapping screw 5x25 | 2   |
| 10   | tapping screw 5x8  | 1   |
| 11   | muffler cover stay | 1   |
| 12   | plate set          | 1   |
| 13   | screw washer 5x12  | 1   |
| 14   | spring washer      | 1   |

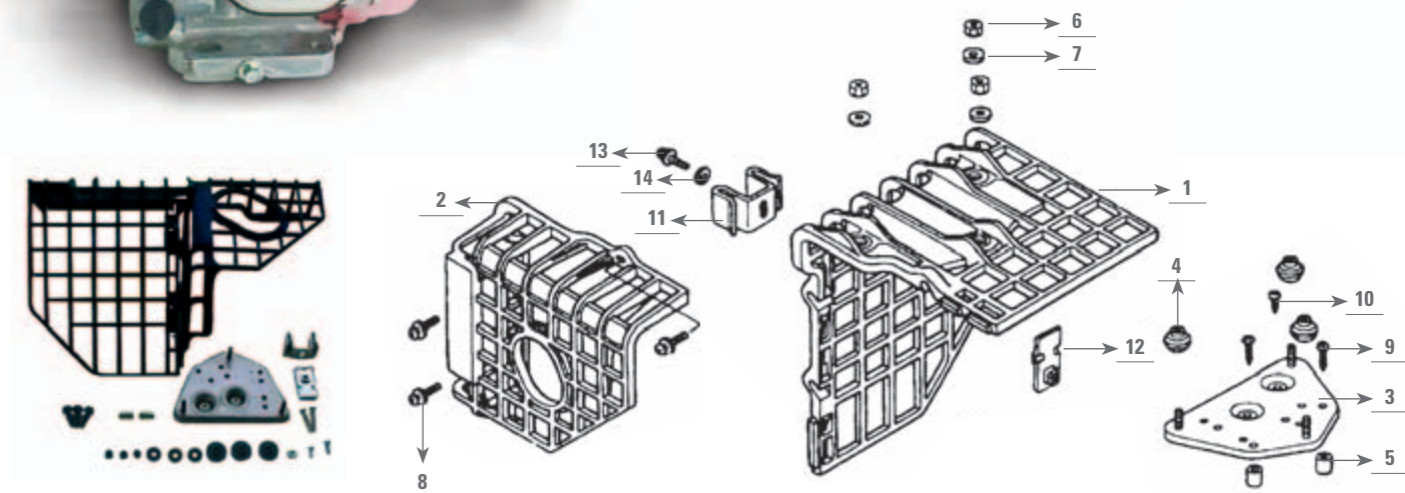
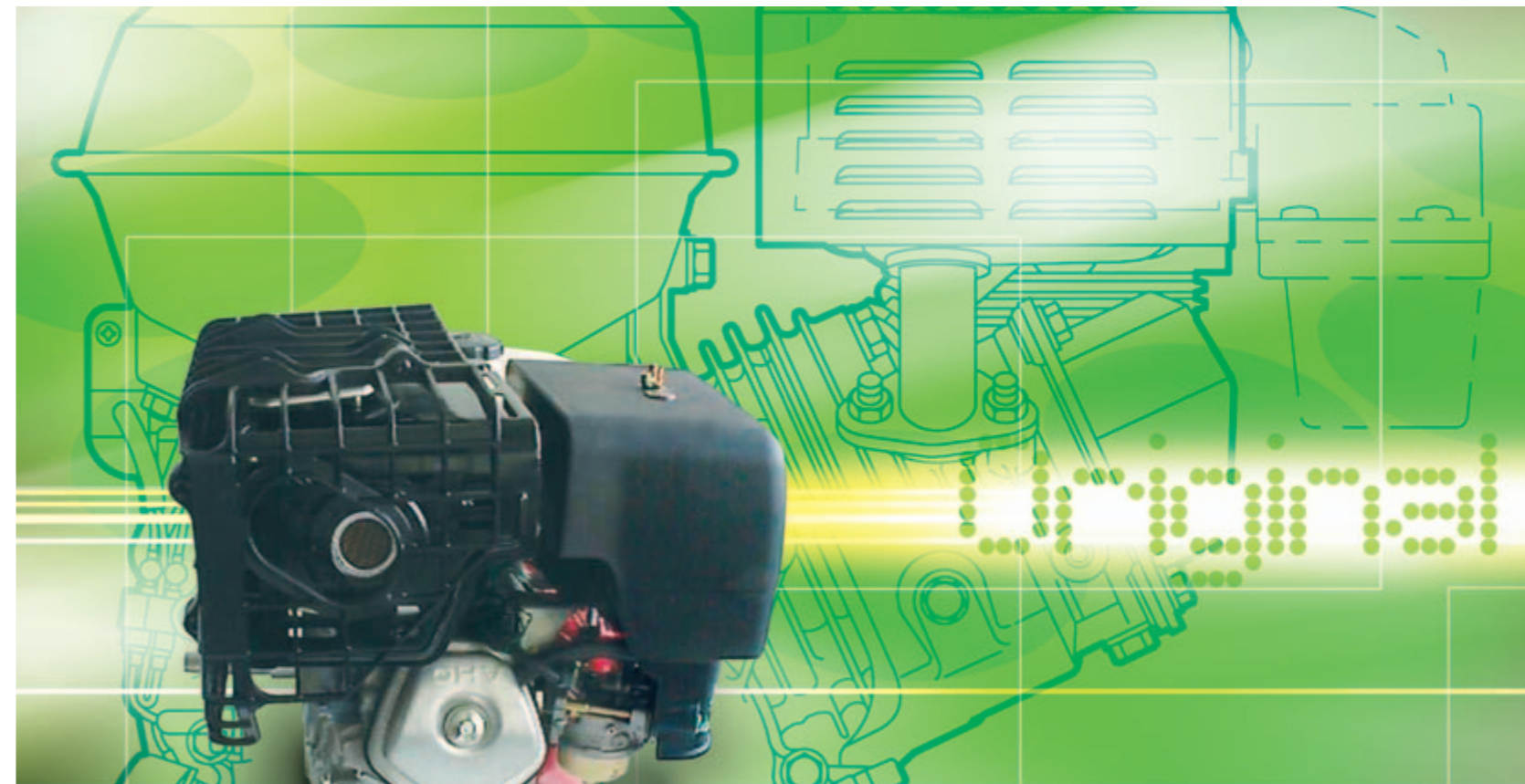

Remark tapping screw (ref 9)  
Must be mounted in holes '4' mentioned on base comp.(ref 3)

# En-muffler guard (plastic type) with deflector

| Heat protection and deflection of exhaust gas for | Partnumber     | Packing     |
|---|----------------|-------------|
| GX 240K1 / GX 270, 270T (std muffler)             | 06185-ZK9-W500 | 1 piece/set |

| REF. | Component name           | QTY |
|------|--------------------------|-----|
| 1    | muffler cover comp.      | 1   |
| 2    | rear muffler cover comp. | 1   |
| 3    | muffler cover base comp. | 1   |
| 4    | muffler cover spacer     | 3   |
| 5    | air cleaner case collar  | 2   |
| 6    | hex.nut 5mm              | 3   |
| 7    | plain washer 5mm         | 3   |
| 8    | screw washer 6x20        | 3   |

| REF. | Component name     | QTY |
|------|--------------------|-----|
| 9    | tapping screw 5x25 | 2   |
| 10   | tapping screw 5x8  | 1   |
| 11   | muffler cover stay | 1   |
| 12   | plate set          | 1   |
| 13   | screw washer 5x12  | 1   |
| 14   | spring washer      | 1   |
| 15   | deflector          | 1   |
| 16   | tapping screw 4x6  | 2   |

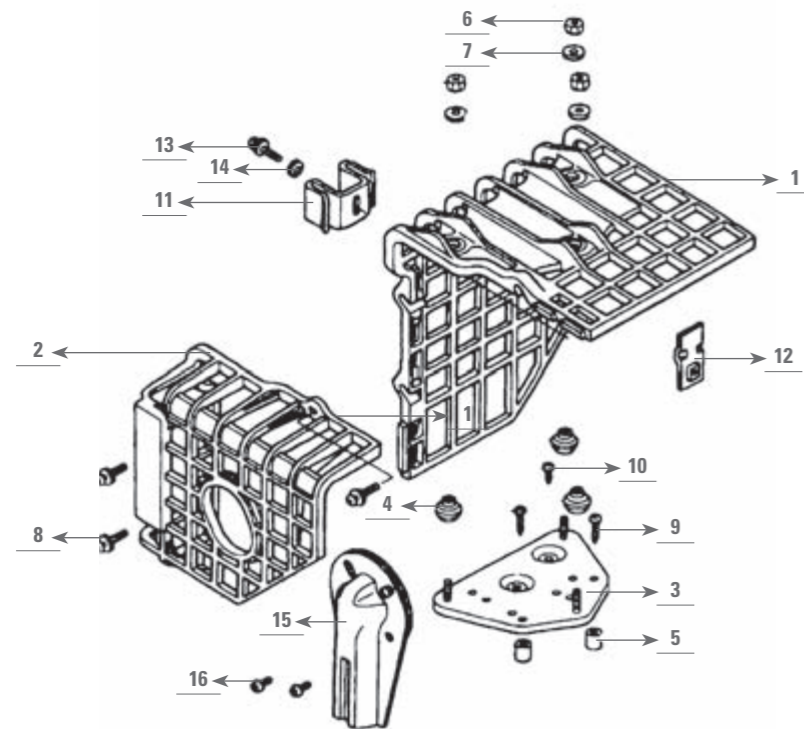
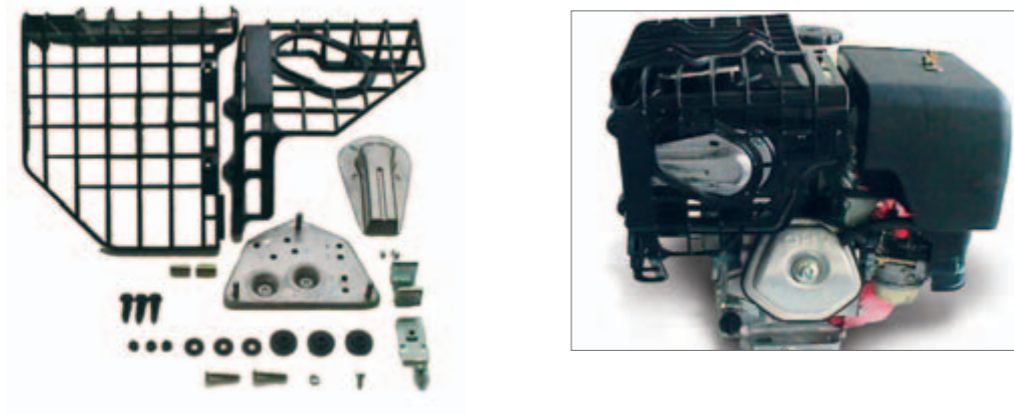

Remark tapping screw (ref 9)  
Must be mounted in holes '4' mentioned on base comp.(ref 3)

# Universal muffler for v-twin engine

| Engine model   | Partnumber     | Packing     |
|--|----------------|-------------|
| GX(V) 610K1 / 620 K1 / 670,<br>GCV 520 / 530 and GXV 520 / 530 | 06183-ZJ1-BOSU | 1 piece/set |

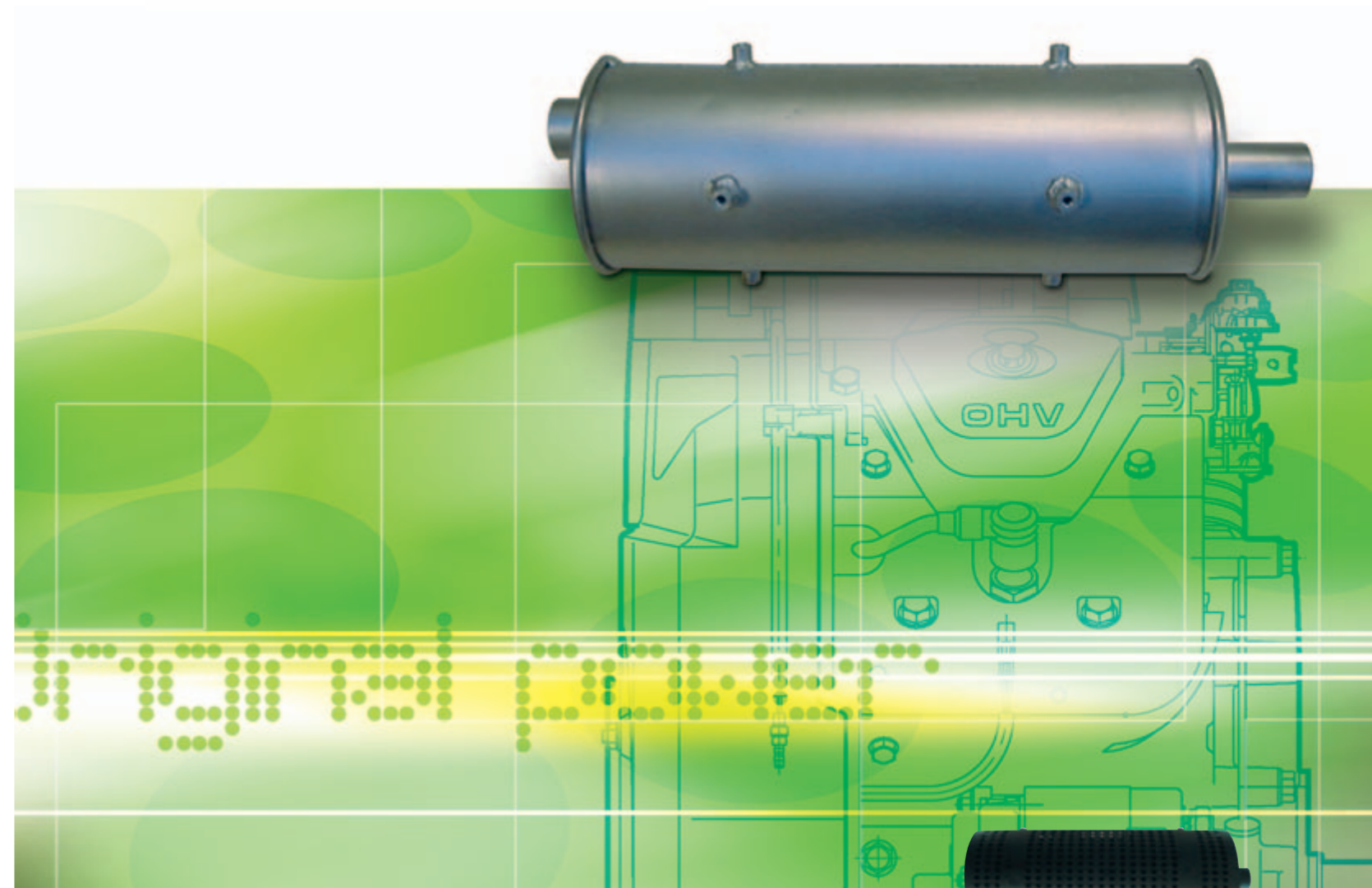

## Top mount muffler

| Muffler for                  | Partnumber     | Packing     |
|------------------------------|----------------|-------------|
| GX 610K1 / GX 620K1 / GX 670 | 06183-ZJ1-BOSL | 1 piece/set |

| REF. | Component name    | QTY |
|------|-------------------|-----|
| 1    | top mount muffler | 1   |
| 2    | mounting bolt     | 4   |

Attention  
Left = starter motor side exhaust



# Top mount muffler

| Muffler for                | Partnumber     | Packing     |
|----------------------------|----------------|-------------|
| GX 610K1, GX 620K1, GX 670 | 06183-ZJ1-BOSR | 1 piece/set |

| REF. | Component name    | QTY |
|------|-------------------|-----|
| 1    | top mount muffler | 1   |
| 2    | mounting bolt     | 4   |

*Attention*  
Right = oil filter side exhaust

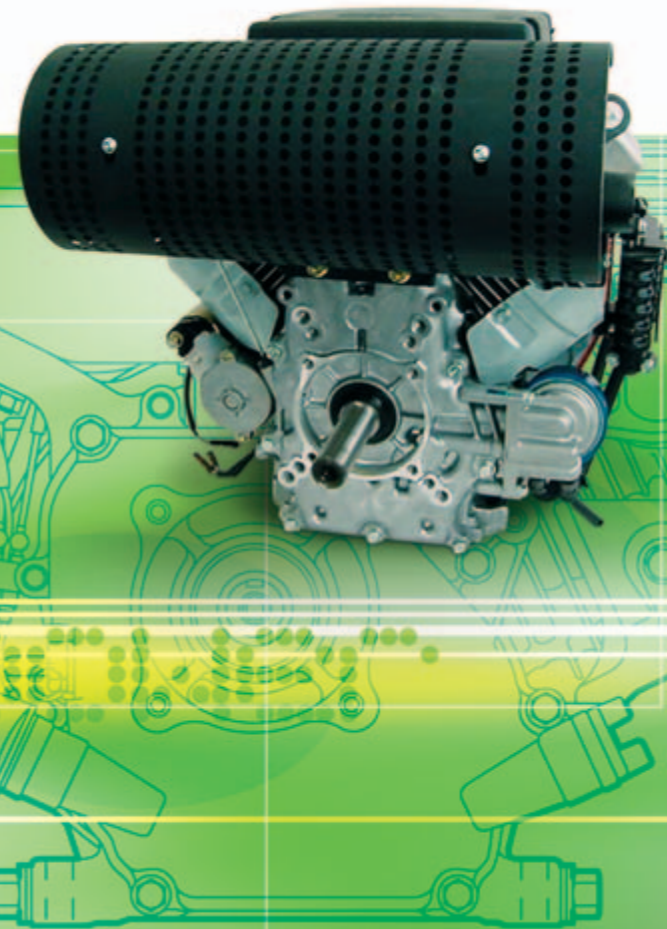
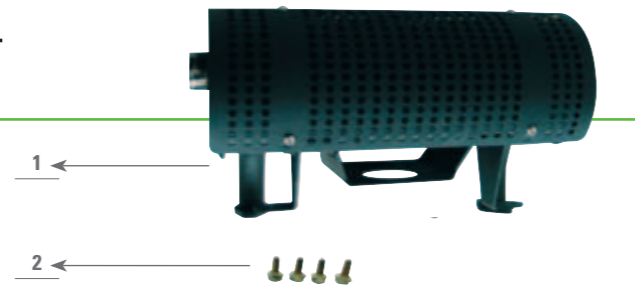

# Deflector

| 90° deflector pipe for top mount muffler on | Partnumber    | Packing     |
|---|---------------|-------------|
| GX 610K1 / GX 620K1 / GX 670                | 18431-ZH8-BOS | 1 piece/set |

| REF. | Component name | QTY |
|------|----------------|-----|
| 1    | deflector      | 1   |
| 2    | clamp          | 1   |
| 3    | washer         | 2   |
| 4    | nut            | 2   |



# Exhaust flange

| Welding flange for exhaust pipe                  | Partnumber   | Packing      |
|--|--------------|--------------|
| GX(V)610 / 620, GX(V)610K1, GX(V)620K1, GX(V)670 | GX620-000001 | 2 pieces/set |



# Heat shield

| Heat protector plate for   | Partnumber    | Packing     |
|--|---------------|-------------|
| Top mount muffler on GX 610K1 / GX 620K1<br>GX 670 equipped with plastic fuel tank | 18434-ZJ1-BOS | 1 piece/set |



*Attention*  
Heat shield installation is obligatory when plastic fuel tank is mounted!

# Exhaust pipe

| Exhaust pipe for             | Partnumber    | Packing      |
|------------------------------|---------------|--------------|
| GCV 520 / 530, GXV 520 / 530 | 18331-20A-SET | 2 pieces/set |

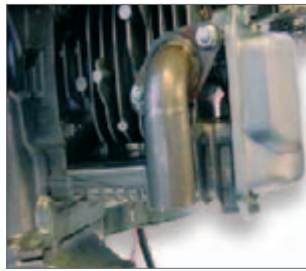

# Deflector (short type)

| Deflection of exhaust gases for   | Partnumber  | Packing     |
|---|-------------|-------------|
| GX 120K1, 120T1 / 160K1, 160T1 / 200, 200T / 240K1 / 270, 270T / 340K1 / 390K1, 390T1 | GX20-000-00 | 1 piece/set |

| REF. | Component name       | QTY |
|------|----------------------|-----|
| 1    | deflector            | 1   |
| 2    | tapping screw (M4x6) | 4   |

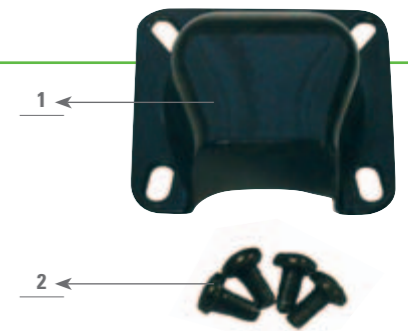

# Low noise muffler

| Super silent muffler for   | Partnumber    | Packing     |
|----------------------------|---------------|-------------|
| GX 340K1 / GX 390K1, 390T1 | 18310-ZB8-SIL | 1 piece/set |

| REF. | Component name      | QTY |
|------|---------------------|-----|
| 1    | muffler comp.       | 1   |
| 2    | exhaust pipe        | 1   |
| 3    | gasket exhaust pipe | 2   |
| 4    | hex.bolt 8x28       | 2   |
| 5    | flange nut 10mm     | 2   |

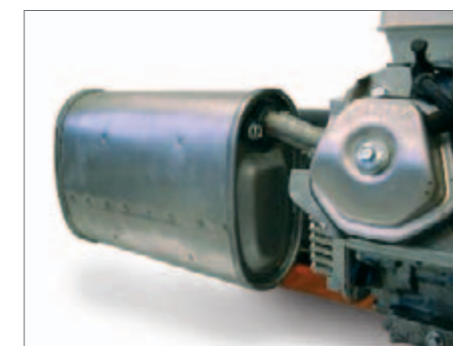

*Remark*  
Flange nut 10mm is used as spacer to tighten the exhaust pipe onto the cylinder head.

# Deflector (long type)

| Deflector of exhaust gases for  | Partnumber     | Packing     |
|---|----------------|-------------|
| GX 120K1, 120T1 / 160K1, 160T1 / 200, 200T / 240K1 / 270, 270T / 340K1 / 390K1, 390T1 | 18431-ZH8-W500 | 1 piece/set |

| REF. | Component name       | QTY |
|------|----------------------|-----|
| 1    | deflector            | 1   |
| 2    | tapping screw (M4x6) | 4   |

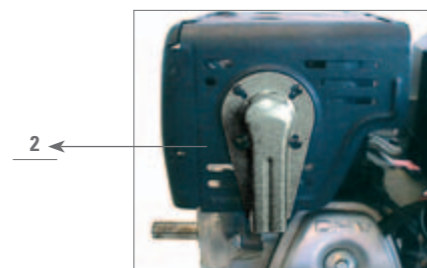



## Pipe comp., ex. (high-r)

| Engine model          | Partnumber    | Packing     |
|-----------------------|---------------|-------------|
| GX610K1 / 620K1 / 670 | 18330-ZJ1-841 | 1 piece/set |



## Pipe comp., ex. (high-l)

| Engine model          | Partnumber    | Packing     |
|-----------------------|---------------|-------------|
| GX610K1 / 620K1 / 670 | 18330-ZJ1-851 | 1 piece/set |



## Pipe comp., ex. (side-l)

| Engine model    | Partnumber    | Packing     |
|-----------------|---------------|-------------|
| GX610K1 / 620K1 | 18330-ZJ1-861 | 1 piece/set |

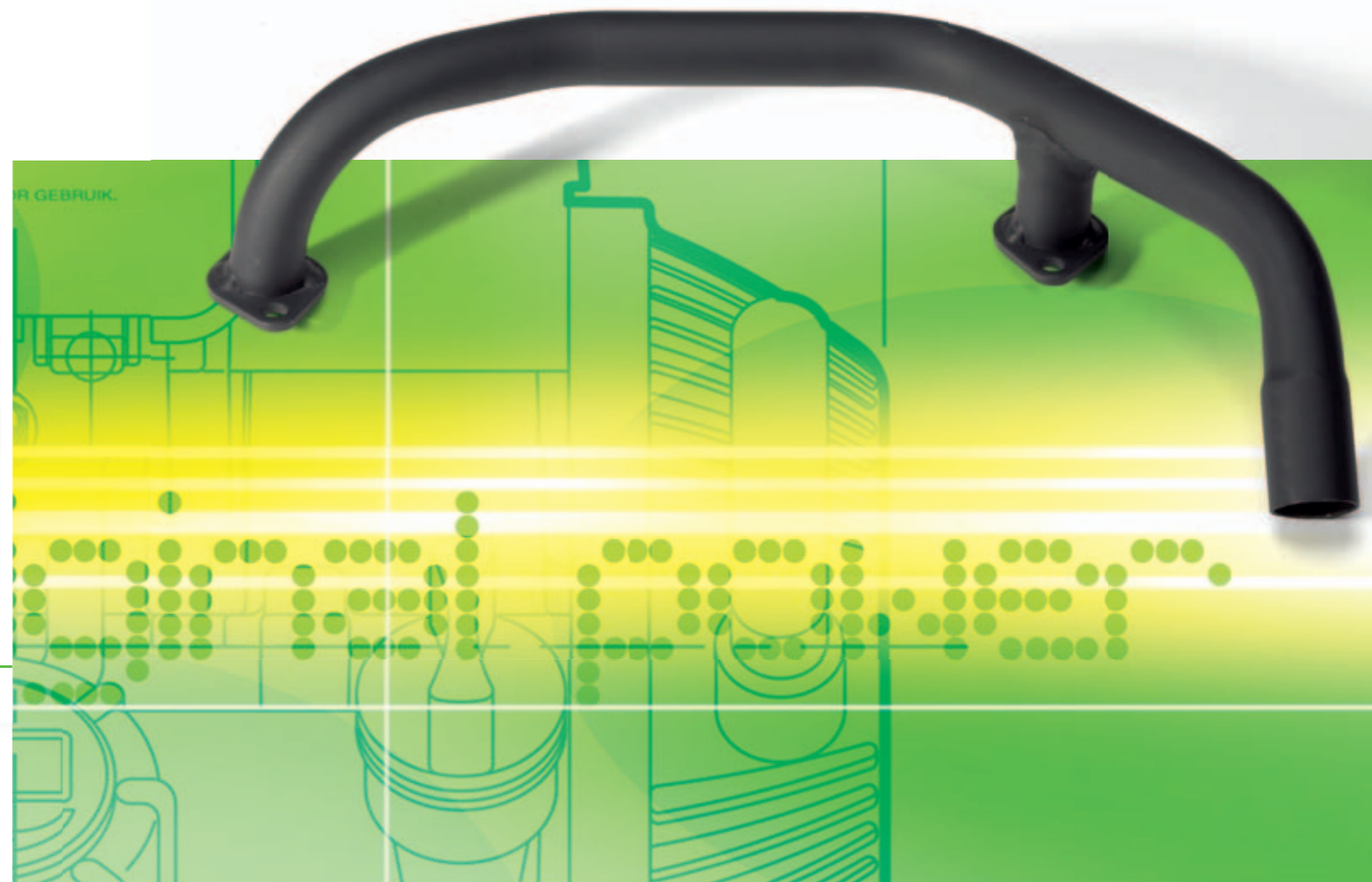

## Spark arrester

| Engine model              | Partnumber    | Packing     |
|---------------------------|---------------|-------------|
| GX610K1 / GX620K1 / GX670 | 18355-ZN1-003 | 1 piece/set |



# Joint assy., connecting tube

| Engine model      | Partnumber    | Packing     |
|-------------------|---------------|-------------|
| GX610K1 / GX620K1 | 17415-ZJ1-840 | 1 piece/set |



# Switch, oil pressure

| Engine model                                     | Partnumber    | Packing     |
|--|---------------|-------------|
| GX(V)610 / 620, GX(V)610K1, GX(V)620K1, GX(V)670 | 37240-ZG3-E01 | 1 piece/set |



# Dual function hour & tachometer

| Engine model | Partnumber      | Packing     |
|--------------|-----------------|-------------|
| All engines  | 08174-ZL8-000HE | 1 piece/set |



# Valve, oil shut-off

| Engine model                                     | Partnumber      | Packing     |
|--|-----------------|-------------|
| GX(V)610 / 620, GX(V)610K1, GX(V)620K1, GX(V)670 | 15558-ZJ1-010AH | 1 piece/set |

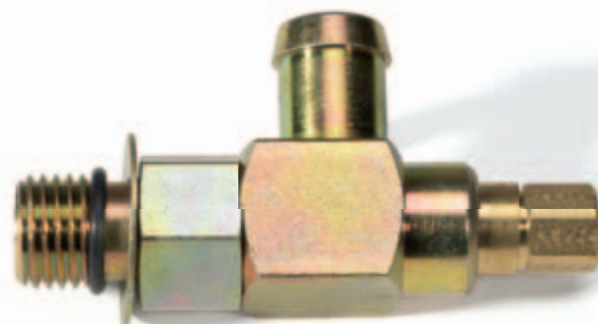

# Screen grid (P.T.O.)

| Engine model                                     | Partnumber    | Packing     |
|--|---------------|-------------|
| GX(V)610 / 620, GX(V)610K1, GX(V)620K1, GX(V)670 | 28454-ZJ1-KIT | 1 piece/set |

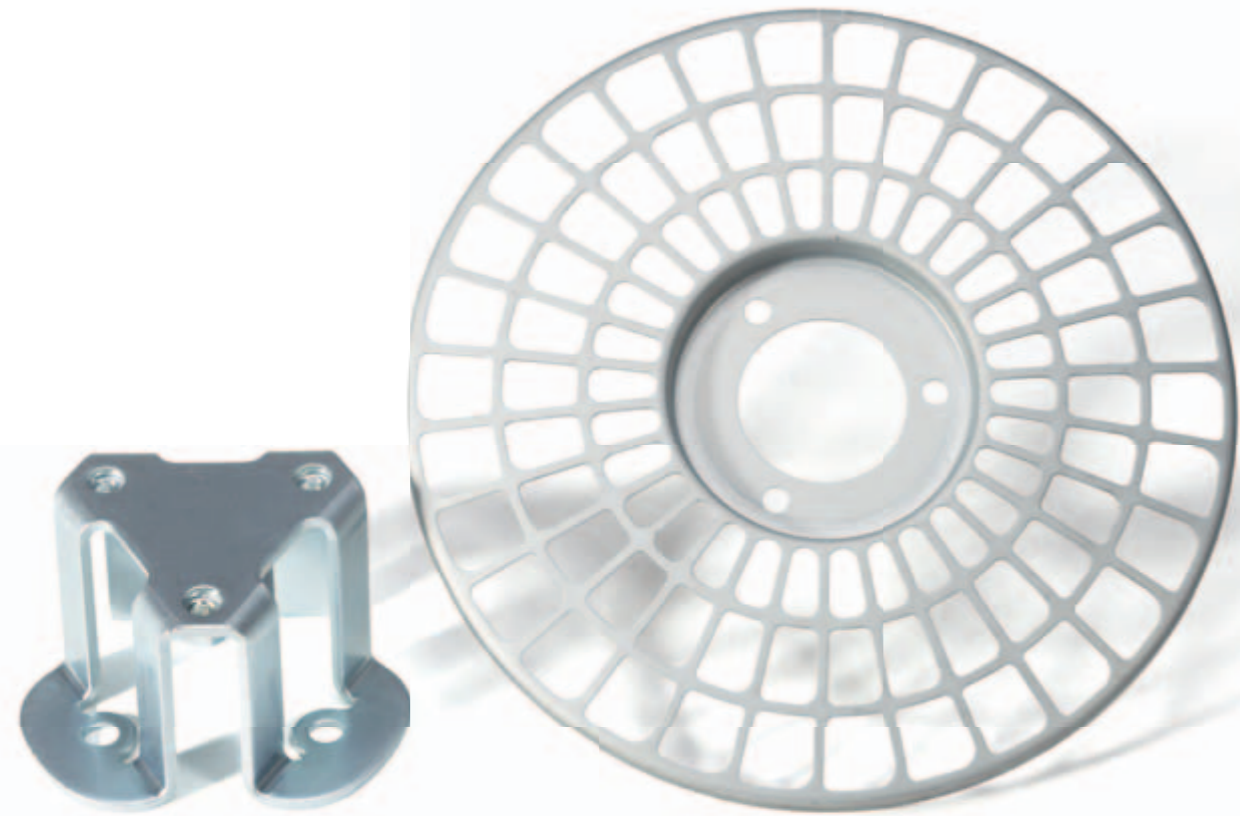

# Shaft, fr. P.T.O.

| Engine model    | Partnumber    | Packing     |
|-----------------|---------------|-------------|
| GX620 / GX620K1 | 23311-ZJ1-KIT | 1 piece/set |

| REF.          | Component name    | QTY |
|---------------|-------------------|-----|
| 23311-ZJ1-H10 | Shaft, fr. P.T.O. | 1   |
| 90111-KT0-670 | Mounting bolt     | 3   |



# Switch assy, engine stop

| Engine model | Partnumber    | Packing     |
|--------------|---------------|-------------|
| GX440IU      | 35120-Z2E-003 | 1 piece/set |

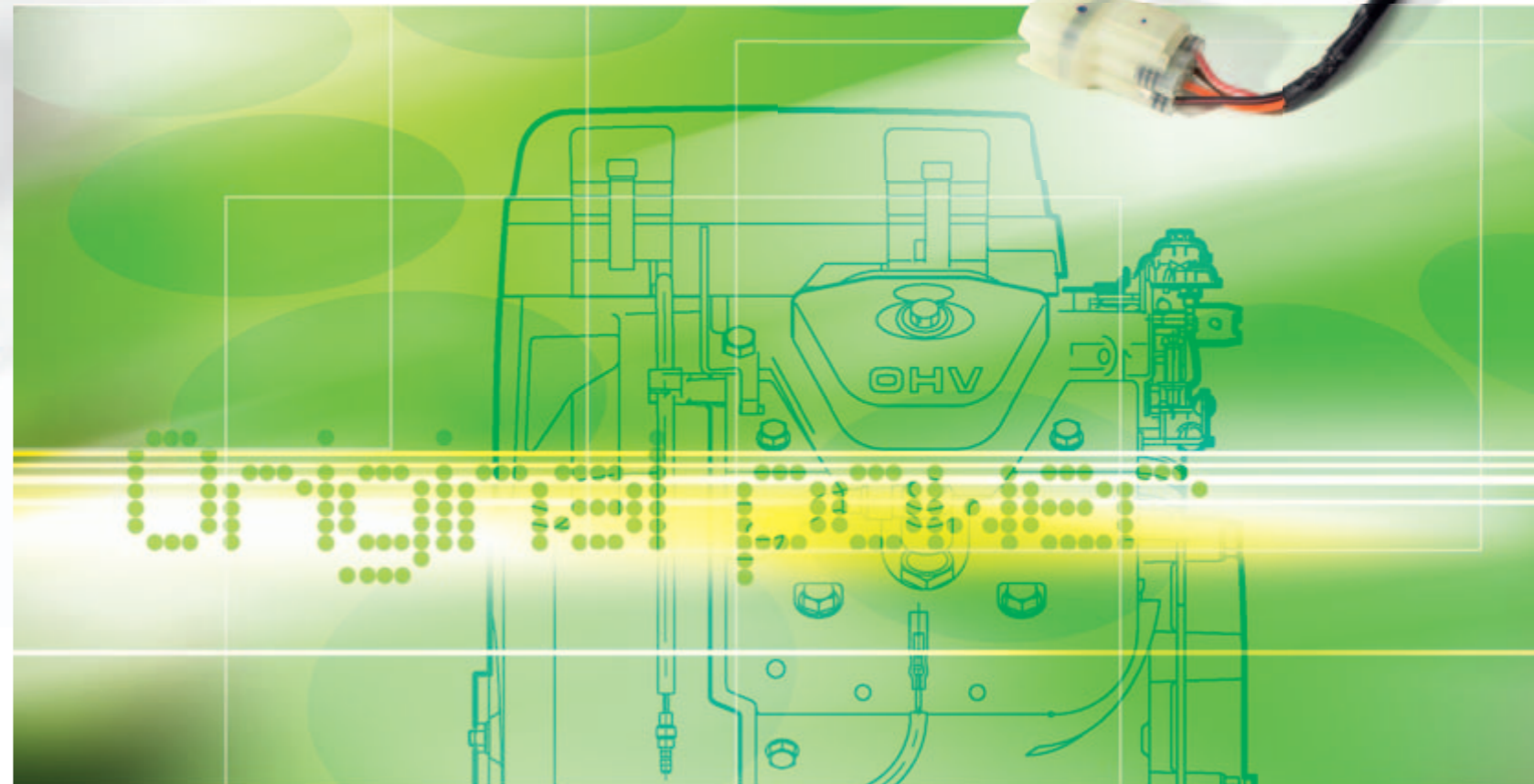

# Switch assy combination (remote, with fuse)

| Engine model | Partnumber    | Packing     |
|--------------|---------------|-------------|
| GX440IU      | 35100-Z2E-003 | 1 piece/set |

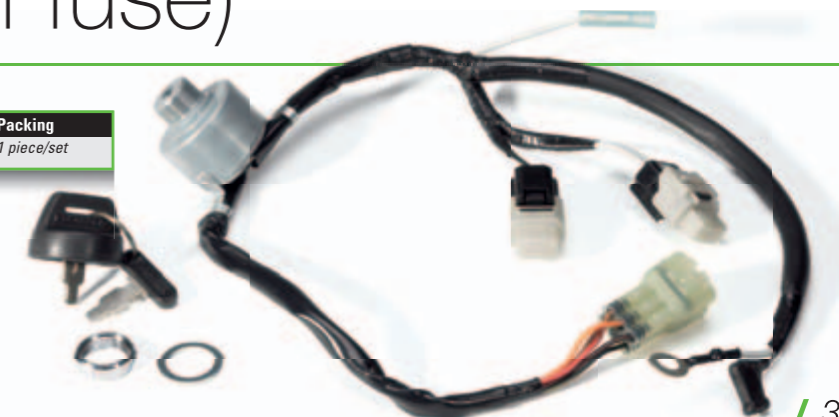

## Switch assy combination (remote, w/o fuse)

| Engine model | Partnumber     | Packing     |
|--------------|----------------|-------------|
| GX440IU      | 35100-Z2E-X010 | 1 piece/set |

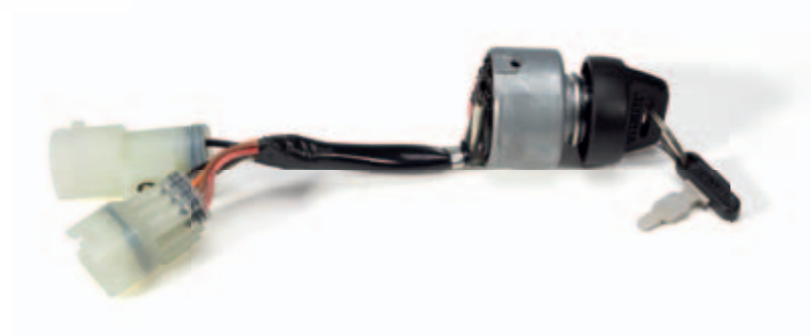

## Volume assy, speed

| Engine model | Partnumber    | Packing     |
|--------------|---------------|-------------|
| GX440IU      | 35570-Z2E-004 | 1 piece/set |



## Extension harness, for combination switch with fuse

| Engine model | Partnumber                            | Packing     |
|--------------|---------------------------------------|-------------|
| GX440IU      | 35105-Z2E-X000 (WIRE LENGTH = 200 cm) | 1 piece/set |



## Ext. harness assy, subwire (6p & 3 terminals)

| Engine model | Partnumber                           | Packing     |
|--------------|--------------------------------------|-------------|
| GX440IU      | 32105-Z2E-X000 (wire length= 300 cm) | 1 piece/set |

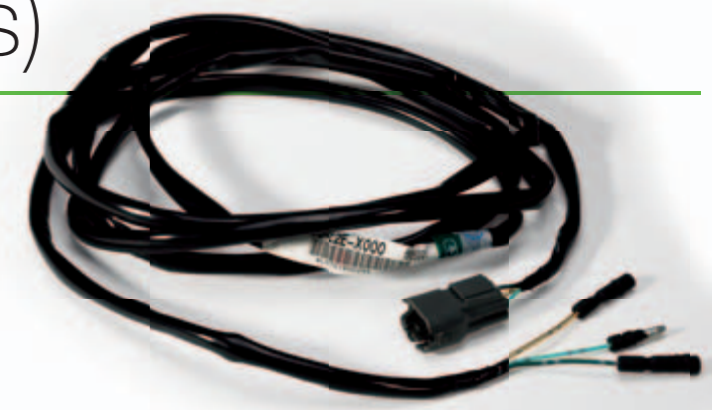

# Ext. harness assy, subwire (6p & 6p)

| Engine model | Partnumber                            | Packing     |
|--------------|---------------------------------------|-------------|
| GX440IU      | 32105-ZZE-X010 (wire length = 300 cm) | 1 piece/set |



# Coupler, short (switch 1 function)

| Engine model | Partnumber     | Packing     |
|--------------|----------------|-------------|
| GX440IU      | 32130-ZZE-0001 | 1 piece/set |

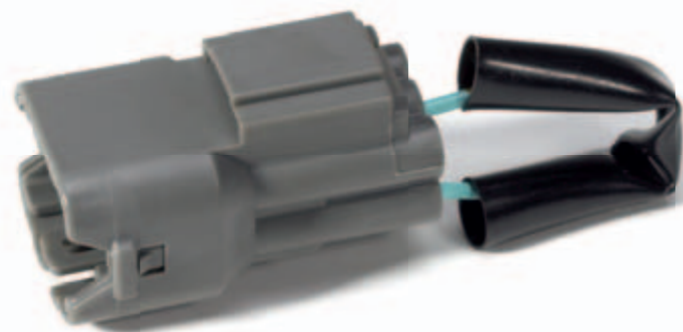

# 6p, gray (volume switch), male

| Engine model | Partnumber | Packing     |
|--------------|------------|-------------|
| GX440IU      | 6187-6809  | 1 piece/set |

### Wiring instructions for IGX:

- Wiring for the potentiometer and mode switch should be as short as possible.
  - Honda recommends less than 5m.
  - Less than 2m is recommended for engine switches (combination switch and engine stop switch).
- Diameter of wiring should be 0,5 mm<sup>2</sup>.
- Refer to the iGX Matching manual for more info on wiring.

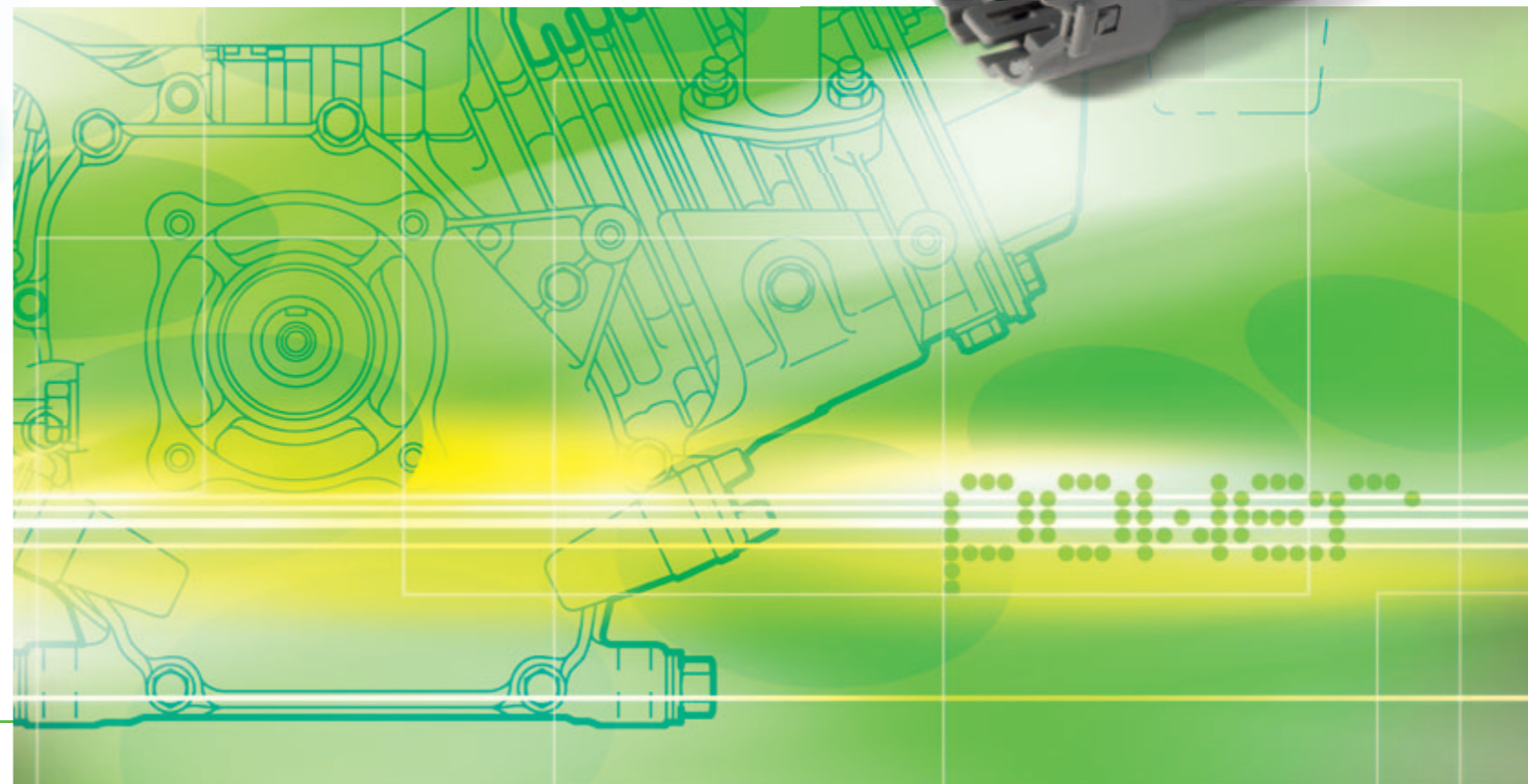

# 6p, gray (volume switch), female

| Engine model | Partnumber | Packing     |
|--------------|------------|-------------|
| GX440IU      | 6180-6187  | 1 piece/set |

### Wiring instructions for IGX:

- Wiring for the potentiometer and mode switch should be as short as possible.
  - Honda recommends less than 5m.
  - Less than 2m is recommended for engine switches (combination switch and engine stop switch).
- Diameter of wiring should be 0,5 mm<sup>2</sup>.
- Refer to the iGX Matching manual for more info on wiring.



# 4p, blue (communication port), male

| Engine model | Partnumber | Packing     |
|--------------|------------|-------------|
| 6187-4445    | 6187-4445  | 1 piece/set |

### Wiring instructions for IGX

- Wiring for the potentiometer and mode switch should be as short as possible.
  - Honda recommends less than 5m.
  - Less than 2m is recommended for engine switches (combination switch and engine stop switch).
- Diameter of wiring should be 0,5 mm<sup>2</sup>.
- Refer to the iGX Matching manual for more info on wiring.

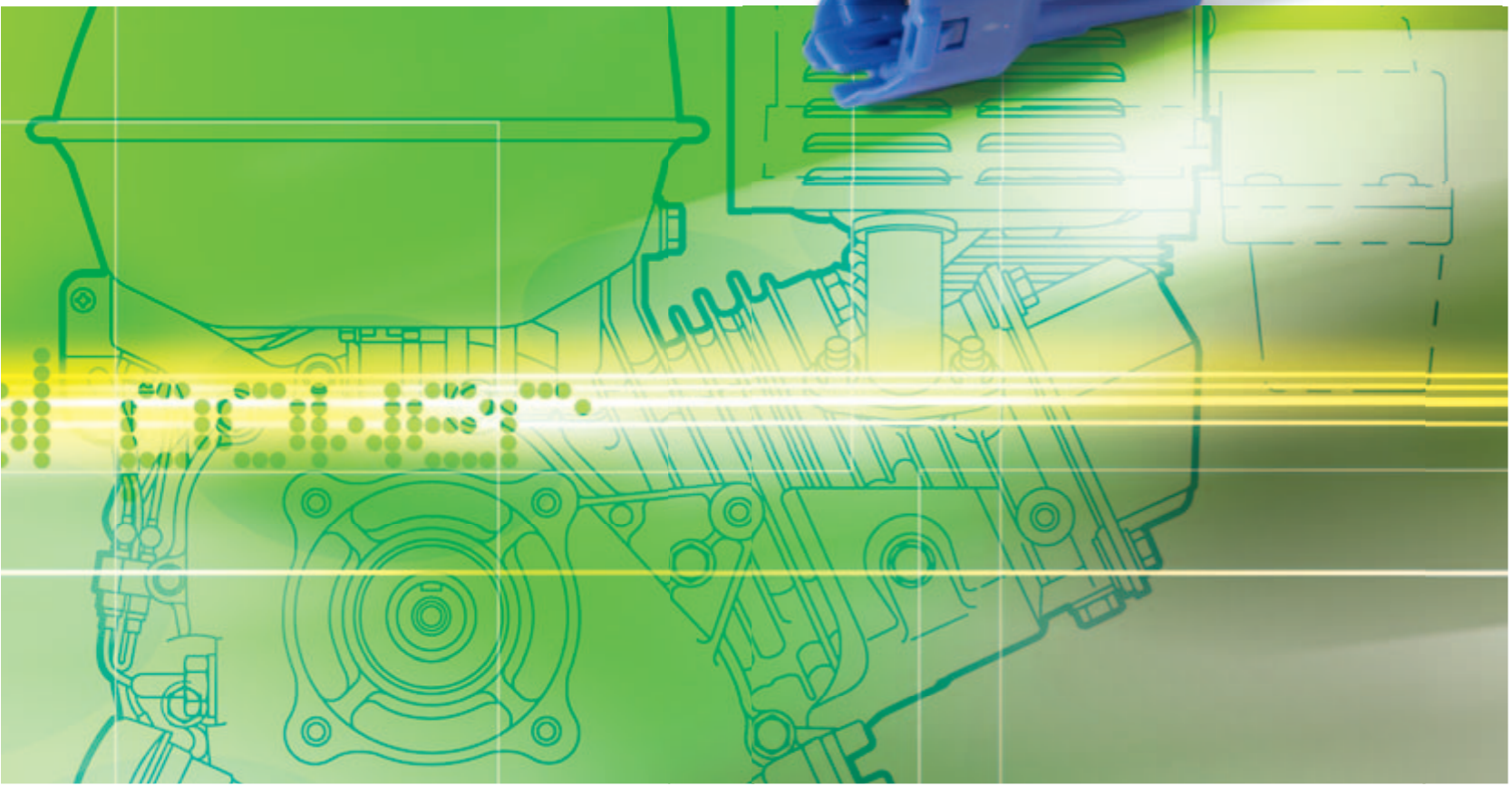
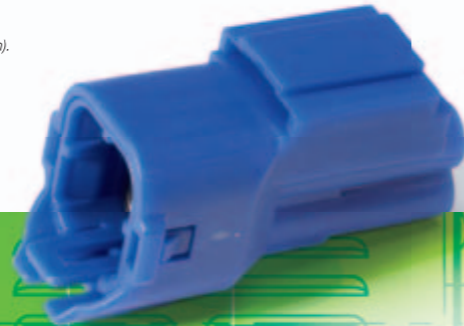

# 4p, blue (communication port), female

| Engine model | Partnumber | Packing     |
|--------------|------------|-------------|
| GX440IU      | 6180-4185  | 1 piece/set |

### Wiring instructions for IGX:

- Wiring for the potentiometer and mode switch should be as short as possible.
  - Honda recommends less than 5m.
  - Less than 2m is recommended for engine switches (combination switch and engine stop switch).
- Diameter of wiring should be 0,5 mm<sup>2</sup>.
- Refer to the iGX Matching manual for more info on wiring.



# Dummy plug

| Engine model | Partnumber | Packing       |
|--------------|------------|---------------|
| GX440IU      | 7160-9465  | 10 pieces/set |



# Wire seal

| Engine model | Partnumber | Packing       |
|--------------|------------|---------------|
| GX440IU      | 7160-8234  | 10 pieces/set |



# Terminal, male

| Engine model | Partnumber | Packing       |
|--------------|------------|---------------|
| GX440IU      | 1500-0105  | 10 pieces/set |



# Terminal, female

| Engine model | Partnumber | Packing       |
|--------------|------------|---------------|
| GX440IU      | 1500-0106  | 10 pieces/set |



## 2p coupler kit (female)

| Engine model | Partnumber     | Packing     |
|--------------|----------------|-------------|
| GX440U       | 9845F-00002-00 | 1 piece/set |

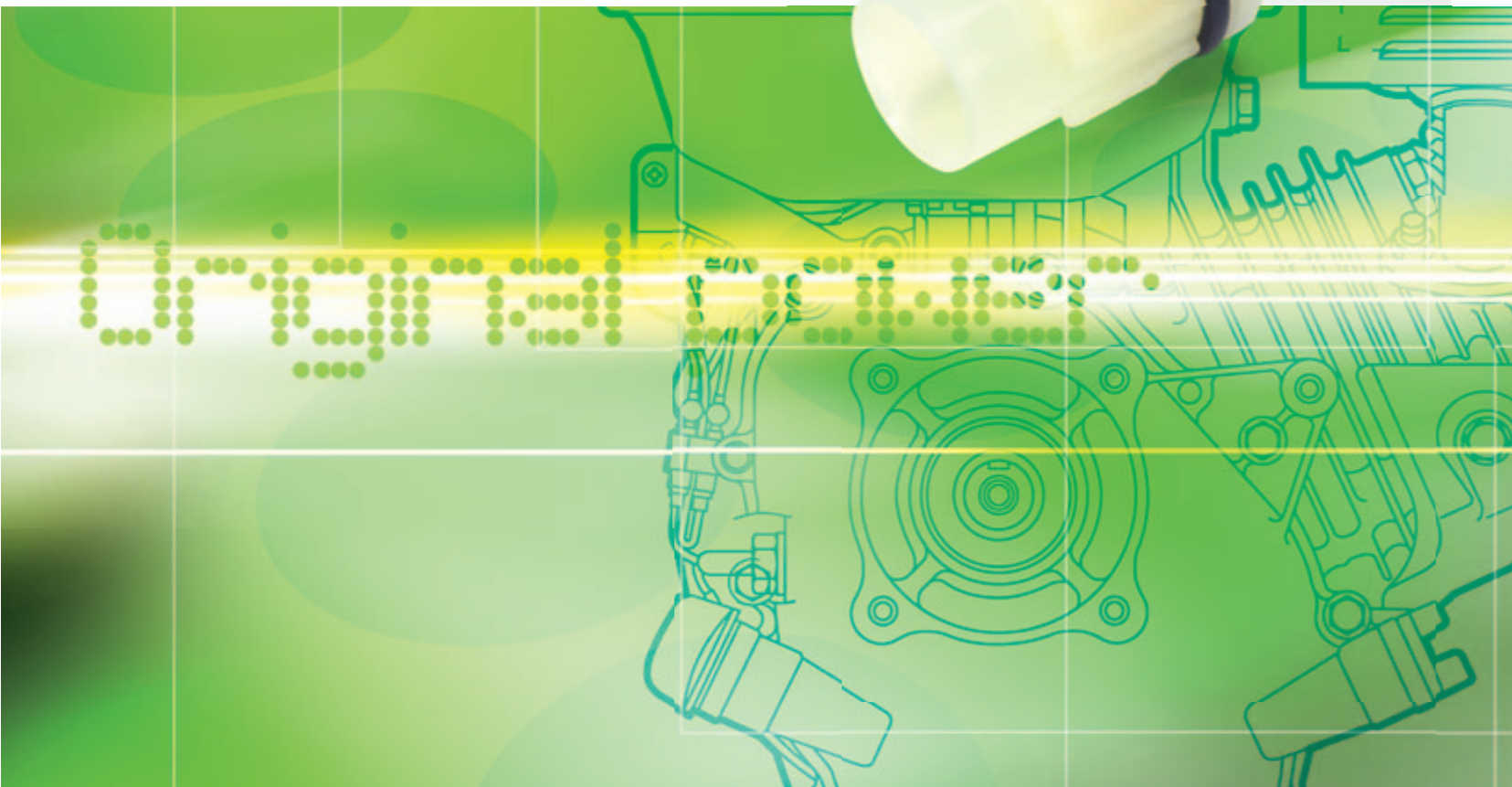

## Str govern (overwrite kit)

| Engine model | Partnumber | Packing     |
|--------------|------------|-------------|
| GX440U       | IGXST-KIT  | 1 piece/set |



## 2p coupler kit (male)

| Engine model | Partnumber     | Packing     |
|--------------|----------------|-------------|
| GX440U       | 9835F-10002-00 | 1 piece/set |



# V-twin winter kit

| Engine model | Partnumber    | Packing     |
|--------------|---------------|-------------|
| GX610/620    | 06192-ZJ1-800 | 1 piece/set |

Can be used if temperature is below 7°C,  
if temperature is above 7°C then original  
covers should be mounted again.



## ENG IMPORTANT

Every effort has been made to ensure accuracy and comprehensiveness of the information included in this catalogue. However, Honda Europe cannot be held responsible for errors or omissions and for alterations occurred after release for printing.

## FR IMPORTANT

Tous les efforts ont été faits pour assurer l'exactitude et l'exhaustivité de l'information contenue dans ce catalogue. Néanmoins, Honda Europe ne peut porter la responsabilité d'erreurs ou d'annulations et de modifications intervenues après l'autorisation d'impression.

## D WICHTIG

Die Ihnen vorliegende Information wurde nach bestem Wissen und Gewissen zusammengestellt. Für Irrtümer oder Änderungen und den daraus resultierenden Schäden kann keine Gewähr übernommen werden.

## NL BELANGRIJK

Al het mogelijke werd gedaan om de juistheid en volledigheid van de geboden informatie in deze catalogus te garanderen. Honda Europe kan evenwel niet aansprakelijk worden gesteld voor fouten of weglatingen en voor wijzigingen die na de vrijgave voor de druk zijn voorgekomen.

## E IMPORTANTE

Se han realizado todos los esfuerzos posibles para garantizar la fiabilidad de este catálogo. No obstante, Honda Europa no se responsabiliza de los errores, omisiones o alteraciones que puedan producirse tras su impresión.

## I IMPORTANTE

Tutti gli sforzi sono stati fatti per assicurare l'esattezza e la completezza delle informazioni contenute in questo catalogo. In ogni caso, la società Honda Europe non potrà essere ritenuta responsabile per errori, modifiche o annullamenti verificatisi dopo l'autorizzazione alla stampa.

## P IMPORTANTE

Todos os esforços foram feitos para assegurar a exactidão da informação contida neste catálogo. No entanto, a Honda Europe não se responsabiliza por qualquer tipo de erro ou anulação após dada a autorização para impressão.

## FI TÄRKEÄÄ

Olemme pyrkineet tekemään tämän luettelon niin täsmälliseksi ja kattavaksi kuin mahdollista. Honda Europe ei kuitenkaan vastaa painatuksen jälkeen tapahtuneista muutoksista.

## DK VIGTIGT

Der er lagt stor vægt på at gøre informationerne i dette katalog så korrekt og omfattende som muligt. Honda Europe kan dog ikke stilles til ansvar for fejl eller udeladelser samt ændringer der er sket efter kataloget er frigivet til trykning.

## N VIKTIG

Det er lagt stor vekt på å gjøre informasjonen i denne katalogen så korrekt og omfattende som mulig. Honda reserverer seg fra eventuelle trykkfeil samt endringer som har skjedd etter publisering.

## S VIKTIGT

Stor vikt har lagts på att göra informationen i denna katalog så korrekt och omfattande som möjligt. Honda reserverar sig för feltryck samt ändringar som gjorts efter att katalogen gått i tryck.

## CZ DŮLEŽITÉ

Byla věnována velká pozornost přesnosti a rozsahu informací obsažených v tomto katalogu. Nicméně, Honda Europe nenese odpovědnost za chyby nebo opomenutí a za změny které nastanou po vytištění.